



# INSTALLATION & OWNER'S MANUAL

# AIR CONDITIONER

Please read this installation manual completely before installing the product.  
Installation work must be performed in accordance with the national wiring standards  
by authorized personnel only.  
Please retain this installation manual for future reference after reading it thoroughly.  
Please read this manual carefully before operating your set and retain it  
for future reference.

Air-cooled Inverter Scroll Chiller  
ACHH Series  
Original instruction



P/NO : MFL67262615

Copyright © 2018 LG Electronics Inc. All Rights Reserved.

[www.lg.com](http://www.lg.com)

- SVENSKA
- ENGLISH
- NORSK
- ITALIANO
- DANSK
- ESPAÑOL
- FRANÇAIS
- DEUTSCH
- EMHNIKA
- ČEŠTINA
- NEDERLANDS
- POLSKI
- IMBA ROMÂNĂ

## TIPS FOR SAVING ENERGY

Here are some tips that will help you minimize the power consumption when you use the air conditioner. You can use your air conditioner more efficiently by referring to the instructions below:

- Do not cool excessively indoors. This may be harmful for your health and may consume more electricity.
- Block sunlight with blinds or curtains while you are operating the air conditioner.
- Keep doors or windows closed tightly while you are operating the air conditioner.
- Adjust the direction of the air flow vertically or horizontally to circulate indoor air.
- Speed up the fan to cool or warm indoor air quickly, in a short period of time.
- Open windows regularly for ventilation as the indoor air quality may deteriorate if the air conditioner is used for many hours.
- Clean the air filter once every 2 weeks. Dust and impurities collected in the air filter may block the air flow or weaken the cooling / dehumidifying functions.

### For your records

Staple your receipt to this page in case you need it to prove the date of purchase or for warranty purposes. Write the model number and the serial number here:

Model number : \_\_\_\_\_

Serial number : \_\_\_\_\_

You can find them on a label on the side of each unit.

Dealer's name : \_\_\_\_\_

Date of purchase : \_\_\_\_\_

## IMPORTANT SAFETY INSTRUCTIONS

**READ ALL INSTRUCTIONS BEFORE USING THE APPLIANCE.**

Always comply with the following precautions to avoid dangerous situations and ensure peak performance of your product.

### **WARNING**

It can result in serious injury or death when the directions are ignored

### **CAUTION**

It can result in minor injury or product damage when the directions are ignored

### **WARNING**

- Installation or repairs made by unqualified persons can result in hazards to you and others.
- Installation of all field wiring and components **MUST** conform with local building codes or, in the absence of local codes, with the National Electrical Code 70 and the National Building Construction and Safety Code or Canadian Electrical Code and National Building Code of Canada.
- The information contained in the manual is intended for use by a qualified service technician familiar with safety procedures and equipped with the proper tools and test instruments.
- Failure to carefully read and follow all instructions in this manual can result in equipment malfunction, property damage, personal injury and/or death.

### Installation

- Installation is to be performed by qualified personnel who are familiar with local codes and regulations.
  - There is risk of fire, electric shock, explosion, or injury.
- Always install a dedicated circuit and breaker.
  - Improper wiring or installation may cause fire or electric shock.
- For re-installation of the installed product, always contact a dealer or an Authorized Service Center.
  - There is risk of fire, electric shock, explosion, or injury.

4 IMPORTANT SAFETY INSTRUCTIONS

---

- Do not install, remove, or re-install the unit by yourself (customer).
  - There is risk of fire, electric shock, explosion, or injury.
- Prepare for strong wind or earthquake and install the unit at the specified place.
  - Improper installation may cause the unit to topple and result in injury.
- When installing and moving the Product to another site, do not charge it with a different refrigerant from the refrigerant specified on the unit.
  - If a different refrigerant or air is mixed with the original refrigerant, the refrigerant cycle may malfunction and the unit may be damaged.
- Securely install the cover of control box and the panel.
  - If the cover and panel are not installed securely, dust or water may enter the outdoor unit and fire or electric shock may result.
- If the Product is installed in a small room, measures must be taken to prevent the refrigerant concentration from exceeding the safety limit when the refrigerant leaks.
  - Consult the dealer regarding the appropriate measures to prevent the safety limit from being exceeded. Should the refrigerant leak and cause the safety limit to be exceeded, hazards due to lack of oxygen in the room could result.
- Use the correctly rated breaker or fuse.
  - There is risk of fire or electric shock.
- Have all electric work done by a licensed electrician according to regulations and the instructions given in this manual and always use a special circuit.
  - If the power source capacity is inadequate or electric work is performed improperly, electric shock or fire may result.
- There must be no obstruction above the unit.
  - It would deflect discharge air downward where it could be re-circulated back to the inlet of the condenser coil. The condenser fans are propeller type and will not operate with ductwork on the fan outlet.
- When transporting the product, use the forklift or spreader bar in accordance with the manual.
  - Arbitrarily moving the product can cause product damage or injury.

- When moving the product using the forklift, check the weight of the chiller, size and length of the fork to select the appropriate equipment.
  - It can cause damage or injury.
- When hanging the product on the hoist to move the chiller, make sure that the load of the product is evenly distributed and leveled during the move.
  - It can cause damage or injury.
- When moving the product using the spreader bar, make sure to select the spreader bar with material and size to sufficiently support the strength spreader bar.
  - Using inappropriate spreader bar can cause the product to fall and cause injury due to the strength or size.
- Always ground the product.
  - There is risk of fire or electric shock.
- Do not store or use flammable gas or combustibles near the Product.
  - There is risk of fire or failure of product.
- Do not reconstruct to change the settings of the protection devices.
  - If the pressure switch, thermal switch, or other protection device is shorted and operated forcibly, or parts other than those specified by LGE are used, fire or explosion may result.
- Ventilate before operating Product when gas leaked out.
  - It may cause explosion, fire, and burn.
- Use a vacuum pump or Inert (nitrogen) gas when doing leakage test or air purge. Do not compress air or Oxygen and Do not use Flammable gases. Otherwise, it may cause fire or explosion.
  - There is the risk of death, injury, fire or explosion.

### Use

- Do not damage or use an unspecified POWER CABLE.
  - There is risk of fire, electric shock, explosion, or injury.
- Use a dedicated outlet for this appliance.
  - There is risk of fire or electrical shock.
- Be cautious that water could not enter the Product.
  - There is risk of fire, electric shock, or product damage.
- Do not touch the power switch with wet hands.
  - There is risk of fire, electric shock, explosion, or injury.

- When installing and moving the Product to another site, do not charge it with a different refrigerant from the refrigerant specified on the unit.
  - If a different refrigerant or air is mixed with the original refrigerant, the refrigerant cycle may malfunction and the unit may be damaged.
- When the product is soaked (flooded or submerged), contact an Authorized Service Center.
  - There is risk of fire or electric shock.
- Be cautious not to touch the sharp edges and coil.
  - It may cause injury.
- Take care to ensure that nobody could step on or fall onto the outdoor unit.
  - This could result in personal injury and product damage.
- Do not open the inlet grille of the product during operation. (Do not touch the electrostatic filter, if the unit is so equipped.)
  - There is risk of physical injury, electric shock, or product failure.
- Be careful during valve checkout about hot gas line
  - It may become hot enough to cause injury.
- Electric shock hazard. Can cause severe injury or death. Even when power to the panel is off, output board could be connected to high voltage.
- Electric shock hazard. Turn off all power before doing any service.
- Turn the main power off in case of installation or service.

 **CAUTION**

**Installation**

- Always check for gas (refrigerant) leakage after installation or repair of product.
  - Low refrigerant levels may cause failure of product.
- Do not install the product where the noise or hot air from the outdoor unit could damage the neighborhoods.
  - It may cause a problem for your neighbors.
- Keep level even when installing the product.
  - To avoid vibration or water leakage.
- Do not install the unit where combustible gas may leak.
  - If the gas leaks and accumulates around the unit, an explosion may result.

- Do not install the product where it is exposed to sea wind (salt spray) directly.
  - It may cause corrosion on the product. Corrosion, particularly on the condenser and evaporator fins, could cause product malfunction or inefficient operation.
- When installing the unit in a hospital, communication station, or similar place, provide sufficient protection against noise.
  - The inverter equipment, private power generator, high-frequency medical equipment, or radio communication equipment may cause the Product to operate erroneously, or fail to operate. On the other hand, the Product may affect such equipment by creating noise that disturbs medical treatment or image broadcasting.
- Use power cables of sufficient current carrying capacity and rating.
  - Cables that are too small may leak, generate heat, and cause a fire.
- Do not use the product for special purposes, such as preserving foods, works of art, etc. It is a consumer Product, not a precision refrigeration system.
  - There is risk of damage or loss of property.
- Keep the unit away from children. The heat exchanger is very sharp.
  - It can cause the injury, such as cutting the finger. Also the damaged fin may result in degradation of capacity.
- The operator must provide protection against water circuit freezing on all Product units.
  - To prevent damage from freezing water.

### Use

- Do not use the Product in special environments.
  - Oil, steam, sulfuric smoke, etc. can significantly reduce the performance of the Product or damage its parts.
- Make the connections securely so that the outside force of the cable may not be applied to the terminals.
  - Inadequate connection and fastening may generate heat and cause a fire.
- Be sure the installation area does not deteriorate with age.
  - If the base collapses, the Product could fall with it, causing property damage, product failure, or personal injury.

- Install and insulate the drain hose to ensure that water is drained away properly based on the installation manual.
  - A bad connection may cause water leakage.
- Be very careful about product transportation.
  - Do not touch the heat exchanger fins. Doing so may cut your fingers.
  - When transporting the outdoor unit, suspending it at the specified positions on the unit base. Also support the outdoor unit at four points so that it cannot slip sideways.
- Safely dispose of the packing materials.
  - Packing materials, such as nails and other metal or wooden parts, may cause stabs or other injuries.
  - Tear apart and throw away plastic packaging bags so that children may not play with them. If children play with a plastic bag which was not torn apart, they face the risk of suffocation.
- Turn on the power at least 6 hours before starting operation.
  - Starting operation immediately after turning on the main power switch can result in severe damage to internal parts. Keep the power switch turned on during the operational season.
- Do not touch any of the refrigerant piping during and after operation.
  - It can cause a burn or frostbite.
- Do not operate the Product with the panels or guards removed.
  - Rotating, hot, or high-voltage parts can cause injuries.
- Do not directly turn off the main power switch after stopping operation.
  - Wait at least 5 minutes before turning off the main power switch. Otherwise it may result in water leakage or other problems.
- When re-running the product after keep product long time in a low temperature conditions, touch function may not work temporarily.
  - Wait for a time. After time, product work normally.
- Do not insert hands or other objects through the air inlet or outlet while the Product is plugged in.
  - There are sharp and moving parts that could cause personal injury.
- Field wiring must be installed according to unit wiring diagram.
  - It may cause serious electrical damage can occur.



- Do not use an automotive grade antifreeze. Industrial grade glycols must be used. Automotive antifreeze contains inhibitors which will cause plating on the copper tubes within the Product evaporator. The type and handling of glycol used must be consistent with local codes.
- Electrical power must be applied to the compressor crankcase heaters 3 hours before starting unit to drive off refrigerant from the oil.
- Any changes to these parameters must be determined and implemented by qualified personnel with a thorough understanding of how these parameters affect the operation of the unit. Negligent or improper adjustment of these controls can result in damage to the unit or personal injury.
- Service on this equipment is to be performed by qualified refrigeration personnel familiar with equipment operation, maintenance, correct servicing procedures, and the safety hazards inherent in this work. Causes for repeated tripping of equipment protection controls must be investigated and corrected.
- Anyone servicing this equipment shall comply with the requirements set forth by the EPA in regards to refrigerant reclamation and venting.
- This appliance is not intended for use by persons (including children) with reduced physical, sensory or mental capabilities or lack of experience and knowledge, unless they have been given supervision or instruction concerning use of the appliance by a person responsible for their safety.  
Children should be supervised to ensure that they do not play with the appliance.

## TABLE OF CONTENTS

### 2 TIPS FOR SAVING ENERGY

---

### 3 IMPORTANT SAFETY INSTRUCTIONS

---

### 11 PRODUCT INTRODUCTION

---

- 11 General information
- 13 Product information

### 23 CONTROL

---

- 23 Control panel configuration
- 27 Logging in to HMI
- 28 Introduction to HMI menu
- 42 Introduction to schedule menu
- 50 Introduction to record menu
- 52 View setting menu

### 67 FROM INSTALLATION TO TEST RUN

---

### 68 INSTALLATION

---

- 68 Selecting installation location
- 75 Transportation method and precaution
- 77 Installing chiller
- 80 Snow protection
- 81 Water pipe connection
- 87 Electric specification
- 88 Electric work
- 91 How to set control box address (Set cycle PCB address)
- 93 How to install HMI indoors

### 95 TEST RUN/ADDITIONAL FUNCTION

---

- 95 Test run
- 97 Additional function

### 99 SELF DIAGNOSIS FUNCTION

---

### 101 HEAT SOURCE WATER MANAGEMENT

---

- 101 Heat source water management
- 102 Heat source water quality management standard table
- 103 Water pipe side strainer
- 104 Actions for problems in the test operation
- 104 Plate type heat exchanger maintenance
- 105 Daily inspection management

### 107 TROUBLESHOOTING

---

### 117 APPENDIX

---

# PRODUCT INTRODUCTION

## General information

### Product information

Inverter Scroll Chiller of LG Electronics provides cold water for cooling air conditioning system using AHU or FCU etc. Air Cooled R410A Refrigerant Scroll Chiller ACHH Series designed for outdoors is a single unit product of modular type composed of scroll compressor, air cooled condenser, electronic expansion valve, evaporator and LG HMI (Human Machine Interface).

ACHH Series is composed of 2 inverter compressor to form independent refrigerant cycle and one unit module can configure up to maximum of 3 refrigerant cycles and interlock of 5 modules by using AC Smart controller and up to 10 modules by using ACP.

ACHH Series applies the inverter technology to the compressor and condenser fan motor for not only high load but also highly efficient operation in all operating areas.

HMI controller of ACHH Series has the LG's unique control logic to monitor all parameters controlling the operation. These parameters can be controlled to improve the operational efficiency to continuously supply cold water by optimizing to the environment.

Each refrigerant cycle includes the check valve, electronic expansion valve, strainer and refrigerant charge valve. Evaporator connected to the cold water uses the plate type heat exchanger and the condenser uses the air cooled fin and tube heat exchanger.

Inverter Scroll Chiller is a commercial/industrial product.

### Model naming convention

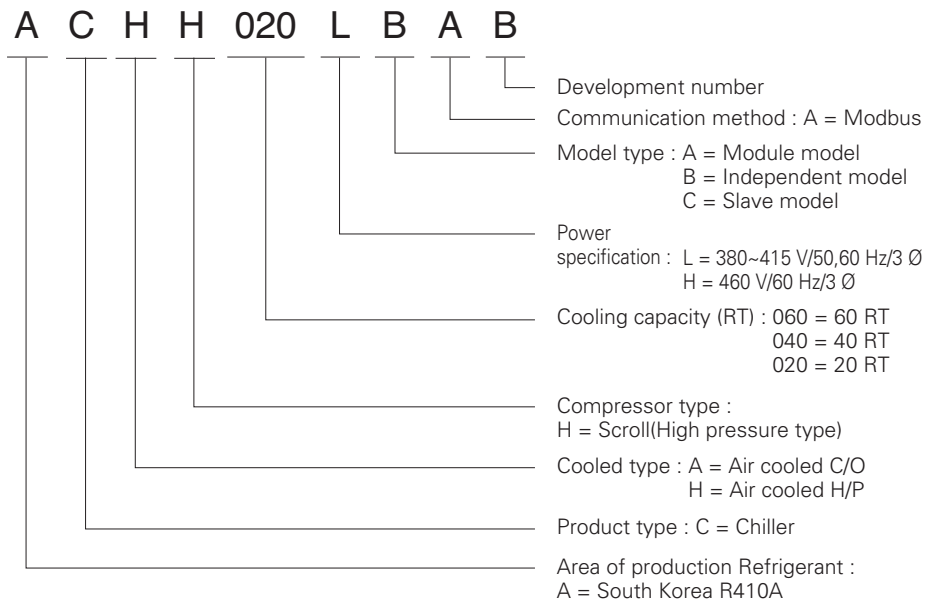

### Airborne Noise Emission

The A-weighted sound pressure emitted by this product is below 70 dB.

The A-weighted sound power of this product is 93 dB.

\*\* The noise level can vary depending on the site.

The figures quoted are emission level and are not necessarily safe working levels. Whilst there is a correlation between the emission and exposure levels, this cannot be used reliably to determine whether or not further precautions are required. Factor that influence the actual level of exposure of the workforce include the characteristics of the work room and the other sources of noise, i.e. the number of equipment and other adjacent processes and the length of time for which an operator exposed to the noise. Also, the permissible exposure level can vary from country to country. This information, however, will enable the user of the equipment to make a better evaluation of the hazard and risk.

**Product information**

Inverter Scroll Chiller		Model	ACHH020LBAB	ACHH023LBAB	ACHH033LBAB	ACHH040LBAB
			H/P	H/P	H/P	H/P
Power		Phase.Lines,V	3,4,380~415	3,4,380~415	3,4,380~415	3,4,380~415
Capacity	Cooling	kW	65.0	74.0	114.0	130.0
		RT	18.5	21.0	32.4	37.0
	Heating	kW	70.3	82.0	120.0	140.6
RT		20	23	34	40	
Input Power	Cooling	kW	22.2	27.4	36.8	44.4
	Heating	kW	21.6	27.3	35.3	43.3
Max operating Current		A	39	48	72	78
Efficiency	Cooling	W/W	2.93	2.70	3.10	2.93
	Heating	W/W	3.25	3.00	3.40	3.25
SEER		W/W	4.40	4.20	4.50	4.40
SCOP		W/W	3.30	3.30	3.30	3.30
Sound Pressure		dB(A)	67	68	68	68
Sound power	Cooling	dB(A)	86	88	85	90
	Heating	dB(A)	86	88	89	90
Compressor	Type	-	Scroll	Scroll	Scroll	Scroll
	No. of Compressor	EA	2	2	4	4
	Oil Type	-	PVE	PVE	PVE	PVE
	Oil charge	cc	1400*2	1400*2	1400*4	1400*4
	Sump Heater	W	60*2	60*2	60*4	60*4
	Type	-	R410A	R410A	R410A	R410A
Refrigrant	Amount of Charged	Kg	7.0 kg X 2	7.0 kg X 2	7.0 kg X 4	7.0 kg X 4
	GWP	-	2087.5	2087.5	2087.5	2087.5
	t-CO <sub>2</sub> eq	-	29.23	29.23	58.45	58.45
	Type	-	plate	plate	plate	plate
Evaporator	Pressure drop	kPa	21.5	28.7	18.7	21.5
	Operating maxium pressure (Refrigrant / Water)	kg/cm <sup>2</sup>	42/10	42/10	42/10	42/10
	Standard Flow (Cooling/Heating)	LPM	186/200	211/235	327/345	372/400
	Inlet/Outlet diameter (Water pipe)	mm	50A/50A	50A/50A	65A/65A	65A/65A
Fan motor	Type	-	BLDC	BLDC	BLDC	BLDC
	No. of Fan	EA	2	2	4	4
	No. of Vanes	EA	4	4	4	4
	Air Flow Rate	CMM	210*2 @1000rpm	210*2 @1000rpm	210*4 @1000rpm	210*4 @1000rpm
	Motor power	W	900*2	900*2	900*4	900*4
Expansion unit		-	EEV	EEV	EEV	EEV
Weight		kg	520	520	990	990
Dimension	W	mm	765	765	1528	1528
	H	mm	2293	2293	2293	2293
	D	mm	2154	2154	2154	2154
Footprint		m <sup>2</sup> /RT	0.089	0.078	0.102	0.089
Protection	High/Low Pressure	-	o	o	o	o
Devices	Anti Frost	-	o	o	o	o
Remote Control		-	Modbus	Modbus	Modbus	Modbus
Power	Power Line	mm <sup>2</sup>	25.0mm <sup>2</sup> *5C	25.0mm <sup>2</sup> *5C	50.0mm <sup>2</sup> *5C	50.0mm <sup>2</sup> *5C
Outlet Temperature	Cooling	°C	5~20	5~20	5~20	5~20
	Heating	°C	30~55	30~55	30~55	30~55
Ambient Temperature	Cooling	°C	-15~48	-15~48	-15~48	-15~48
	Heating	°C	-30~35	-30~35	-30~35	-30~35
Earth Leakage Breaker		A	75	75	125	125
Guaranteed Load Capacity Range			20% ~ 100%			

**Notes :**

1. Due to our policy of innovation some specifications may be changed without prior notification
2. Capacities and Inputs are based on the following conditions  
 Cooling : Outdoor air temp. 35 °C, Water inlet temp. 12 °C, Water Outlet temp. 7 °C  
 Heating : Outdoor air temp. 7 °C, Water inlet temp. 40 °C, Water Outlet temp. 45 °C
3. This product contains fluorinated greenhouse gases (R410A, GWP (Global warning potential) : 2 087.5)  
 t- CO<sub>2</sub> eq = F-gas (kg) x GWP / 1 000

14 PRODUCT INTRODUCTION

Inverter Scroll Chiller		Model	ACHH045LBAB	ACHH050LBAB	ACHH060LBAB	ACHH067LBAB
			H/P	H/P	H/P	H/P
Power		Phase,Lines,V	3,4,380-415	3,4,380-415	3,4,380-415	3,4,380-415
Capacity	Cooling	kW	148.0	171.0	195.0	222.0
		RT	42.1	48.6	55.4	63.1
	Heating	kW	164.0	180.0	210.9	246.0
		RT	47	51	60	70
Input Power	Cooling	kW	54.8	55.2	66.6	82.2
	Heating	kW	54.7	52.9	64.9	82.0
Max operating Current		A	96	108	117	144
Efficiency	Cooling	W/W	2.70	3.10	2.93	2.70
	Heating	W/W	3.00	3.40	3.25	3.00
SEER		W/W	4.20	4.50	4.40	4.20
SCOP		W/W	3.30	3.30	3.30	3.30
Sound Pressure		dBA	68	68	68	68
Sound power	Cooling	dBA	91	88	90	92
	Heating	dBA	93	88	91	92
Compressor		Type	-	Scroll	Scroll	Scroll
		No. of Compressor	EA	4	6	6
		Oil Type	-	PVE	PVE	PVE
		Oil charge	cc	1400*4	1400*6	1400*6
		Sump Heater	W	60*4	60*6	60*6
		Type	-	R410A	R410A	R410A
Refrigerant	Amount of Charged		Kg	7.0 kg X 4	7.0 kg X 6	7.0 kg X 6
	GWP		-	2087.5	2087.5	2087.5
	t-CO <sub>2</sub> eq		-	58.45	87.68	87.68
	Type		-	plate	plate	plate
Evaporator	Pressure drop		kPa	28.7	18.7	21.5
	Operating maxium pressure (Refrigerant / Water)		kg/cm <sup>2</sup>	42/10	42/10	42/10
	Standard Flow (Cooling/Heating)		LPM	411/470	491/518	558/600
	Inlet/Outlet diameter (Water pipe)		mm	65A/65A	65A/65A	65A/65A
	Type		-	BLDC	BLDC	BLDC
Fan motor	No. of Vanes		EA	4	4	4
	Air Flow Rate		CMM	210*4 @1000rpm	210*6 @1000rpm	210*6 @1000rpm
	Motor power		W	900*4	900*6	900*6
	Expansion unit		-	EEV	EEV	EEV
Weight		kg	990	1430	1430	1430
Dimension	W		mm	1528	2291	2291
	H		mm	2293	2293	2293
	D		mm	2154	2154	2154
Footprint		m <sup>2</sup> /RT	0.078	0.101	0.089	0.078
Protection		High/Low Pressure	-	o	o	o
Devices		Anti Frost	-	o	o	o
Remote Control		-	Modbus	Modbus	Modbus	Modbus
Power		Power Line	mm <sup>2</sup>	50.0mm <sup>2</sup> ×5C	95.0mm <sup>2</sup> ×5C	95.0mm <sup>2</sup> ×5C
Outlet Temperature	Cooling		°C	5~20	5~20	5~20
	Heating		°C	30~55	30~55	30~55
Ambient Temperature	Cooling		°C	-15~48	-15~48	-15~48
	Heating		°C	-30~35	-30~35	-30~35
Earth Leakage Breaker		A	125	200	200	200
Guaranteed Load Capacity Range			20% ~ 100%			

**Notes :**

1. Due to our policy of innovation some specifications may be changed without prior notification
2. Capacities and Inputs are based on the following conditions  
Cooling : Outdoor air temp. 35 °C, Water inlet temp. 12 °C, Water Outlet temp. 7 °C
3. This product contains fluorinated greenhouse gases (R410A, GWP (Global warning potential) : 2 087.5)  
t- CO<sub>2</sub> eq = F-gas (kg) x GWP / 1 000

**Product configuration**

This chiller model is configured as shown below.

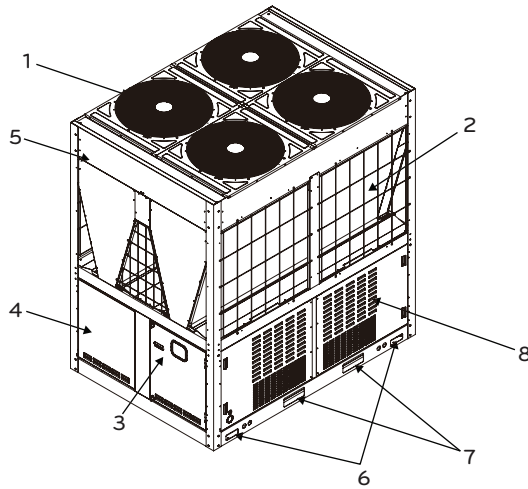

**Legend**

- 1. Fan motor
- 2. Fin & tube heat exchanger
- 3. Main Controller box
- 4. Sub Controller box
- 5. Condenser cover
- 6. Rope support
- 7. Forklift groove
- 8. Side cover

**Cooling cycle**

ACHH Series uses the high pressure type scroll compressor, and the suction gas part is separated from the high pressure discharge part and the motor is installed on the low pressure gas part. Space for motor and storage for refrigerant is secured in the low pressure gas part to increase the reliability for the liquid compression.

Because the sucked refrigerant gas cools the motor and flows to the compressor, separate cooling device to cool the compressor is not required. Inside the system, oil to lubricate the compressor is mixed with the refrigerant to discharge both the oil and refrigerant during the operation. Because the oil discharged from the compressor can reduce the heat transfer efficiency when thick layer is built up on the inner walls of the condenser and evaporator, device to prevent the refrigerant and oil to be discharged together is added to prevent this issue.

This lubrication system ensures longer life for the compressor, improves the sealing of the compression space and provides low noise operation.

As the air cooled fin and tube type heat exchanger, the condenser is composed of heat exchanger in V shape, and the electronic expansion valve is used for efficient control in all load conditions. The controller used in the chiller is exclusively for LG and monitors various sensors installed on the product to protect the product.

For continuous supply of cold and hot water, the product is equipped with maximum continuous operational function and also provides precision control to supply accurate target amount of cold and hot water.

But the protective devices will immediately stop the product when the product reaches abnormal condition or area limit.

In case of an issue, the controller of the chiller will provide helpful diagnostic message to the administrator.

### Description of cooling cycle

The cooling cycle of ACHH Series can be described using the following Pressure – Enthalpy chart.

①, ②, ③, ④ and ⑤ in the following chart shows the conditions of the refrigerant. The refrigerant comes into the compressor motor and cools the motor, and becomes overheated and moves to the suction inlet of the compressor. The oil inside the compressor seals the gap between the compressor scrolls and provides lubrication for the bearing to help the compression of the refrigerant. During this time, the refrigerant is compressed and is discharged to the air cooled condenser. (②) The compressed refrigerant passes through the air cooled condenser and exchanges the heat with the outdoor air. The condensed refrigerant then passes the condenser to be over-cooled. (② → ③ → ④). The refrigerant that passed through the condenser expands in the electronic expansion valve to flow to the evaporator. (④ → ⑤). The refrigerant is evaporated in the plate type heat exchanger, the evaporator. (⑤ → ①) Liquid refrigerant of low temperature pressure passes through the evaporator to cool the water flowing into the evaporator and the refrigerant itself receives the heat to evaporate to gas condition. (①) The refrigerant continues to change the phase and continuously repeats the cooling cycle. For heating, the refrigerant flows in the reverse direction to provide hot water.

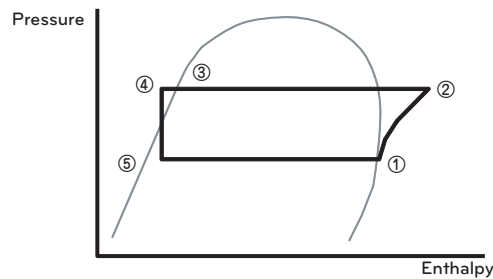

### Lubrication system

Oil is efficiently separated inside the scroll compressor and even when the cycle operates, most of the oil remains inside the scroll compressor. Only part of the oil will be mixed with the refrigerant to be circulated within the cycle.

### Partial load operation

Each cooling cycle operates independently and 1 cooling cycle is composed of 2 inverter compressor as shown below.

2 Inverter compressors increase the RPM after starting to operate to gradually increase the cooling capacity.

The user can operate the product smoothly at optimal condition by setting the cooling capacity based on the linear control of LG Chiller Controller and the product has efficient partial load performance at any load.



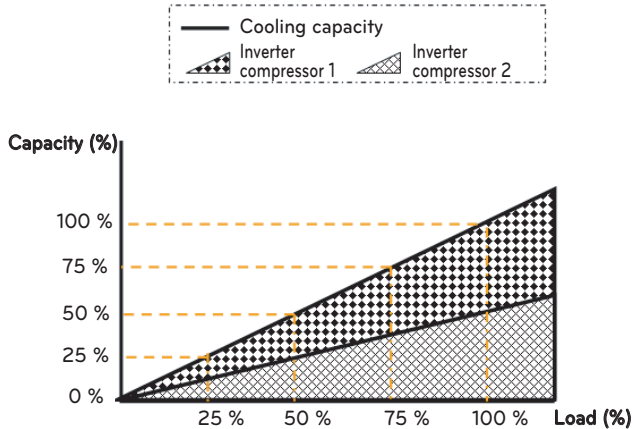

**Cycle configuration and sensor location**

This chiller model is configured as shown below.

**1 UNIT**

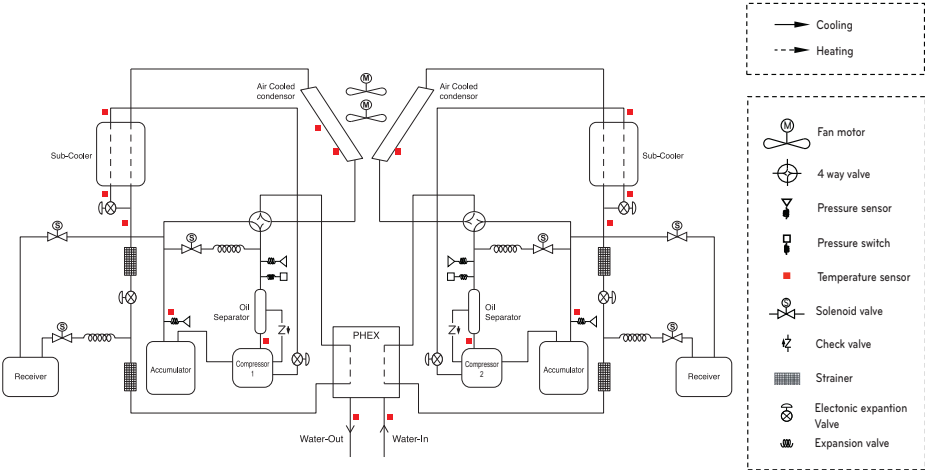

2 UNIT

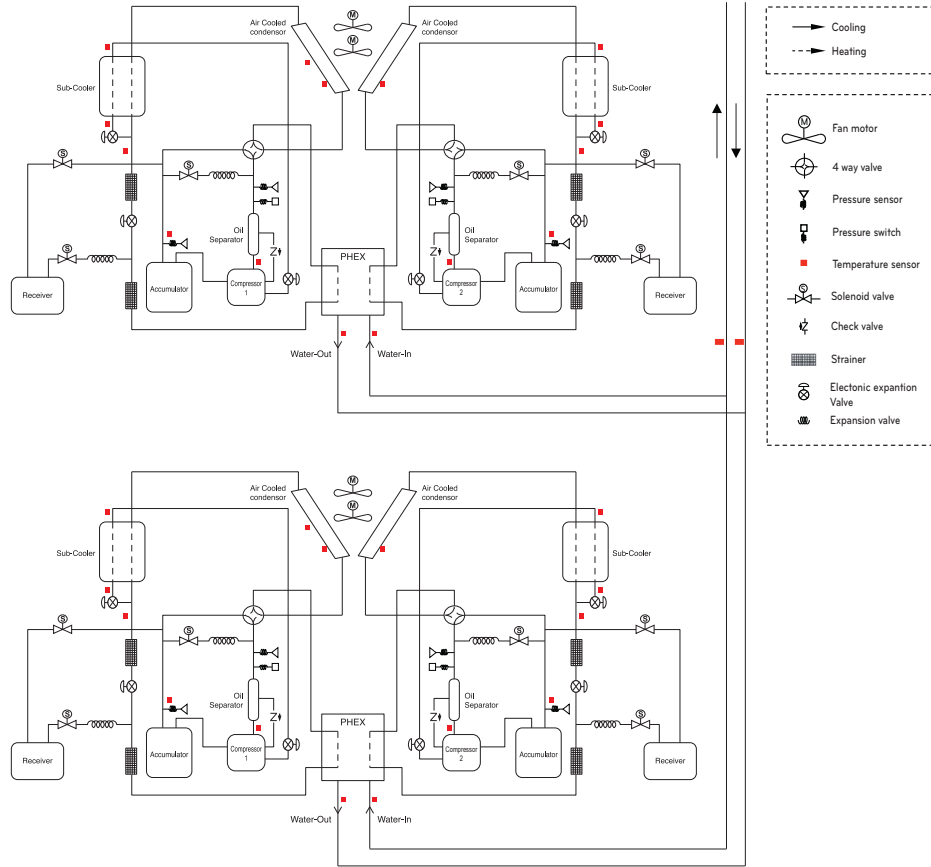

3 UNIT

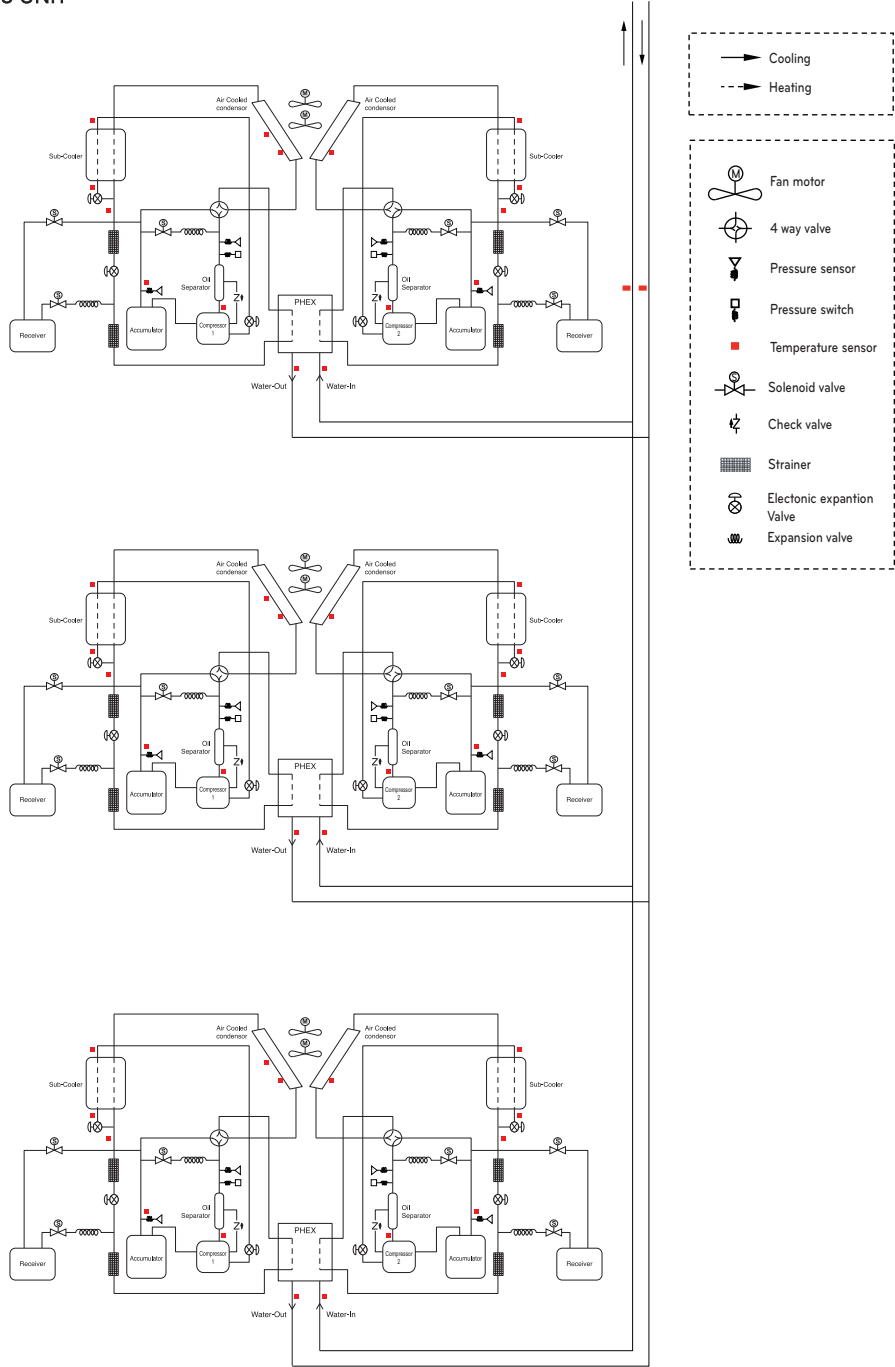

### List of safety device and setting

No.	Safety device	Setting	Function
1	High pressure switch	3.8 MPa	Stops operation of the module when the pressure is above the setting
2	Fuse	250 V 5 A (Main) 250 V 15 A (INV)	Disconnects current when it exceeds the normal value
3	Compressor circuit breaker	35 A	Measures and stops over-current per compressor
4	Fan motor circuit breaker	7 A	Measures and stops over-current per motor
5	Discharge temperature sensor	110 °C	Stops compressor in stages
6	High pressure sensor	3 801 KPa	Starts protective operation control to reduce the cycle pressure
7	Low pressure sensor	0.22 MPa	Starts protective operation control to raise the cycle pressure
8	Water pipe temperature sensor	Off : 3 °C	Prevent evaporator from freezing
9	Reverse phase detector	-	Compares the current of each phase and stops when it is in reverse phase
10	Liquid compressor prevention	-	Discharge over-heating level goes up to prevent liquid compression
11	Compressor ratio limit	9	Compressor frequency is reduced when operating at high compression ratio to prevent the internal parts within the compressor from being damaged

**Operation range and limit**

The following table shows the operation range of the product. Do not operate the product exceeding the following operation range.

**H/P**

Operation range	Voltage		V	342~457
	Cold water inlet temperature		°C	8 or above
	Cold water outlet temperature		°C	5 ~ 20
	Heat water inlet temperature		°C	25 ~ 52
	Heat water outlet temperature		°C	30 ~ 55
	Outdoor temperature	Cooling	°C	-15 ~ 48
Heating		°C	-30 ~ 35	

- (1) Product performance range at rated condition is 20-100 %.
  - Cooling rate condition: Outdoor temperature 35 °C, Water inlet temp. 12 °C. Water Outlet temp. 7 °C
  - Heating rate condition: Outdoor temperature 7 °C, Water inlet temp. 40 °C. Water Outlet temp. 45 °C
- (2) When running heating operating with outdoor temperature is less than 7 °C, Inlet water temperature must be at least 20 °C.

**C/O**

Operation range	Voltage		V	342~457
	Cold water inlet temperature		°C	8 or above
	Cold water outlet temperature		°C	5 ~ 20
	Outdoor temperature	Cooling	°C	-15 ~ 48

- (1) Product performance range at rated condition is 20-100 %.
  - Cooling rate condition: Outdoor temperature 35 °C, Water inlet temp. 12 °C. Water Outlet temp. 7 °C

Operation range of heating mode

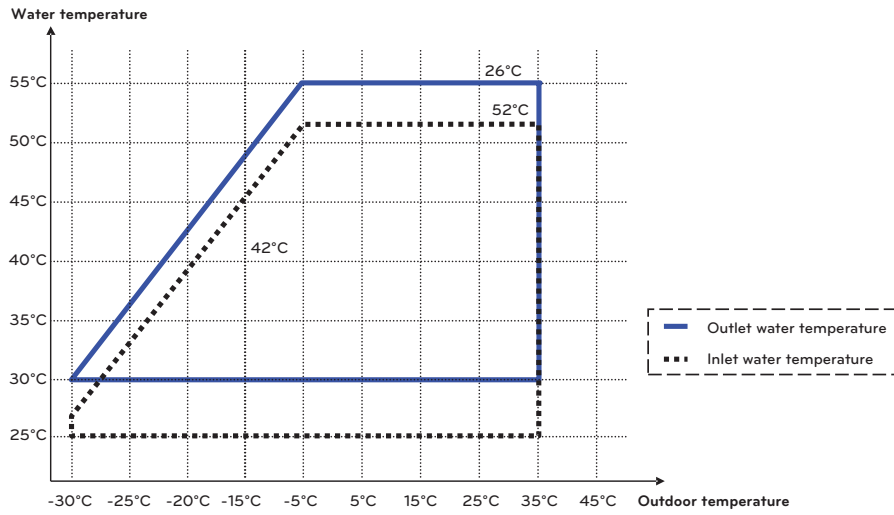

Operation range of cooling mode

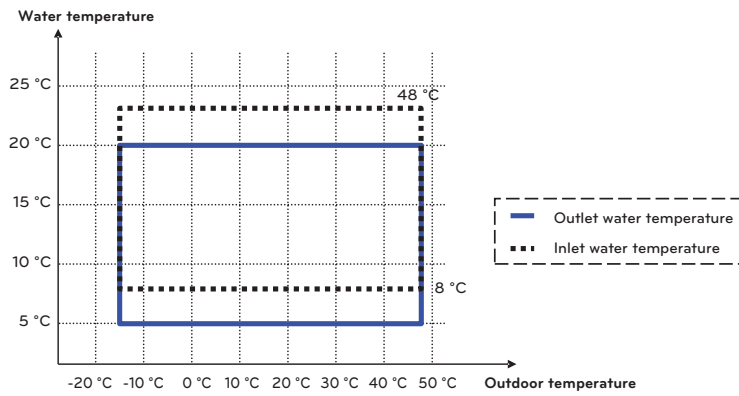

**CAUTION**

When running cooling operation with outdoor temperature is less than -10 °C, depending on inlet temperature, the product does not operate normally, or can take a long time for running. In this case, Please running operation After raising the inlet temperature by circulating load water.

# CONTROL

## Control panel configuration

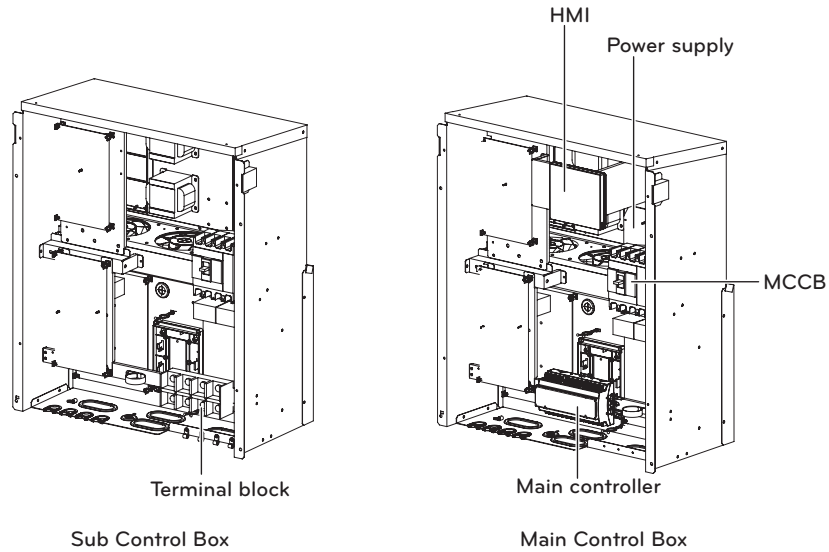

<Inside control panel>

- HMI (Human Machine Interface)  
This is for basic product setting and command, and shows the information of product and each cycle.
- Main controller  
This controls the input/output port and the communication with each cycle.
- Power supply  
This supplies the power to the HMI.
- MCCB (Molded Case Circuit Breaker)  
This shuts off the overcurrent.
- Terminal block  
This is the terminal block that receives the main power externally.

### Chiller controller rotary, dip switch setting

Switch location

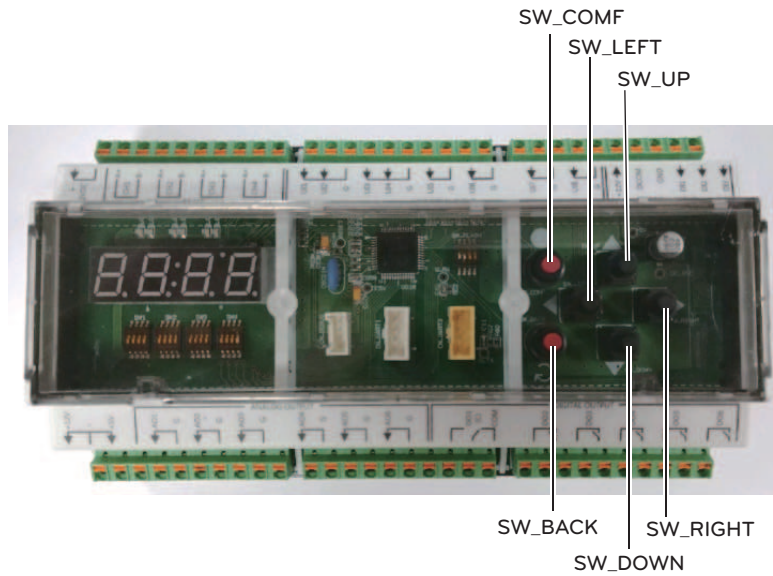

Name	Description
SW_RIGHT	Changes the setting.
SW_UP	Moves the screen.
SW_LEFT	Changes the setting.
SW_DOWN	Moves the screen.
SW_COMF	Sets the selected function.
SW_BACK	Moves to the previous step.

Chiller Controller includes the buttons described above so that the following functions are available for setting without HMI.



### Option Setting

Press SW\_COMF Button to move to O Level Setting Screen.



<Screen>

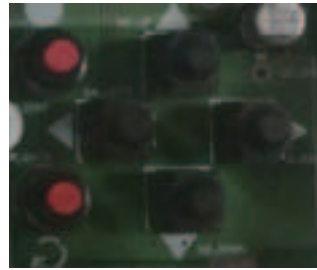

<Button>

Press Up or Down (▲▼) Button to go to a desired function.

If the desired function shows, press SW\_COMF Button.

Then, the Screen moves to 1 Level Setting.

Press Left or Right (◀▶) Buttons to go to a desired function. And Press SW\_COMF Button to set the function.

To go to the previous, press SW\_BACK Button.

	Description	Screen Displays(0 Level)				Screen Displays(1 Level)			
1	Start/Stop	O	P	E	R		R	U	N
						S	T	O	P
2	Cooling/Heating	C	Y	C	L	H	E	A	T
						C	O	O	L
3	Cooling setpoint temperature	C	-	T	E				7
4	Heating setpoint temperature	H	-	T	E			4	5
5	Load outflow Temperature								
6	Control Mode	S	Y	S	1		L	O	C
						D	I	S	T
						S	C	H	E
7	Remote Mode	S	Y	S	2	C	O	N	T
							B	U	S
8	Central Control Address	A	D	D	R				1
9	Maximum Operation Frequency	H	I	-	R		1	1	0
10	Capacity of product	H	P	4	0				
		C	O	4	0				
11	Version			1	0				
		S	V	1	0				

## 26 CONTROL

Description	Screen Display (1 Level)	Detail Description
Start/Stop	RUN /STOP	Set RUN to operate the product and STOP to stop the operation.
Cooling/Heating	HEAT/COOL	Sets the product's Cooling/Heating Operation Mode. COOL selects Cooling Mode and HEAT selects Heating Mode.
Cooling setpoint temperature	7	Sets Cooling Target Temperature. (5 °C~ 20 °C)
Heating setpoint temperature	45	Sets Heating Target Temperature.(30 °C~ 55 °C)
Load outflow water Temperature	-	Shows the temperature value of Load outflow water. (Specified in 0 Level)
Control Mode	LOC/DIST/SCHE	Set's the product's Control Mode. In LOC, the product control is available with HMI and Chiller Controller. DIST refers Remote Control Mode. In SCHE, the product is controlled following the schedule set at HMI.
Remote Mode	CONT/BUS	Sets how to set in Remote Mode. CONT enables the product's operation mode by simple switch contacts. BUS enables the control on the entire product through communication from other communication devices.
Central Control Address	1	The product address can be set for communication with other communication devices. The address can be set by selecting values from 1-247.
Maximum Operation Frequency	110	Sets the Maximum Operation Frequency.(70 Hz~130 Hz)
Capacity of product	-	Shows the current Capacity of product. (Specifies in 0 Level)
Version	-	Shows the program information of Chiller Controller installed in the current product as Version. Version information is subjected to change for improvement of the product performance or the quality improvement. (Specifies in 0 Level)

## Logging in to HMI

This chapter will explain about the composition of each screen in HMI, detail functions, and operation methods. When power is applied to HMI, HMI automatically operates. When HMI starts, Home screen appears.

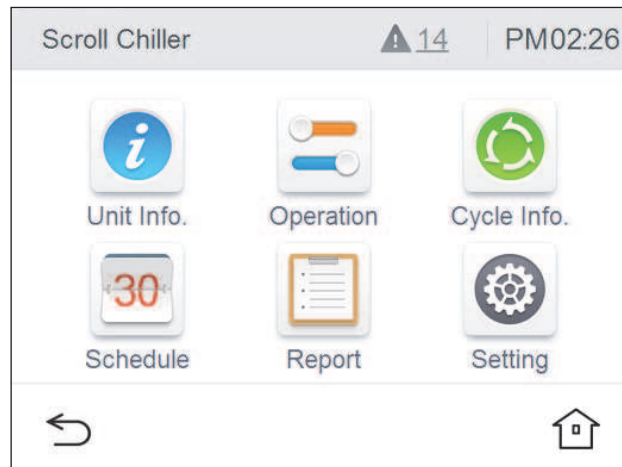

### ! CAUTION

When HMI is installed indoors, the guaranteed communication distance is 500 m.

- Guaranteed communication distance of HMI: 500 m  
(But, when connected indoor, the end resistance (100-200  $\Omega$ ) must be installed at the terminal connected to HMI for smooth communication. In this case, if the installation location of the Unit is different from that of HMI, the maximum permitted connection distance of the communication cable between the two locations is displayed.)

## Introduction to HMI menu

This chapter describes the HMI menus to know to operate the product and how the screen is configured.

### HMI main screen configuration

After logging in to HMI, the system view screen that shows the common information of the product is displayed as shown below.

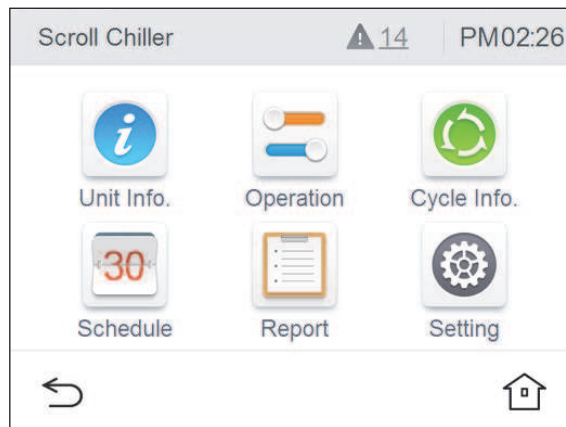

Icon	Description
	You can see the load water temperature, pump/flow amount status, and system information.
	It sets the Start/Stop, Set Temperature, Operation Mode (Only for Heatpump Model), Control Mode, and Max. Operating Frequency are set.
	It checks the individual cycle's operation information.
	It checks the set schedule.
	It checks the occurred error history.
	It sets the installer setting, screen setting, and system setting.
	It returns to the previous menu.
	Home screen appears.

**View chiller information**

Chiller information is composed of the load water temperature, pump/flow amount status, and system information.

- **Load water temperature screen**

Unit Info.	
Load Water Temp.	
E.W.T	0.0°C
L.W.T	0.0°C

Icon	Description
E.W.T	It shows the common load entering water temperature value.
L.W.T	It shows the common load leaving water temperature value.

• Pump/flow amount status screen

Unit Info.	
Pump / Flow Status	Load Water
Pump Output	OFF
Pump Interlock	OFF
Flow Switch	OFF
Capacity	20RT

Icon	Description
Pump Output	<p>If it is in operation, it always maintains ON, and when the product operation is stopped, the freeze and burst mode is applied, and the freeze and burst prevention mode operates as follows.</p> <p>According to the outdoor air temperature condition, the load water pump repeats operation ON and OFF.</p> <p>Outdoor air temperature &lt; 1 °C → always "ON"</p> <p>1 °C ≤ outdoor air temperature &lt; 5 °C → 2 min. operation and 18 min. stop</p> <p>Outdoor air temperature ≥ 5 °C → operation "OFF"</p> <p>The freeze and burst prevention mode is possible when the pump is connected, and to interface with the pump, Pump Output connect shall be connected, and to check whether the pump operates, Pump Interlock connector shall be connected. (For the connector connection method, refer to the connection diagram.)</p>
Pump Interlock	<p>It receives the status of the load water pump output through the external signal contact point of the pump.</p> <p>(When the product is in operation, the pump output shall maintain "ON" state, and otherwise, alarm will occur.)</p>
Flow Switch	<p>It shows the current load water's flow amount switch status value.</p> <p>(When the product is in operation, the pump output shall maintain "ON" state, and otherwise, alarm will occur.)</p>
Capacity	It shows the capacity of the device.

- System information screen

Unit Info.	
System Information	
Setting Temp.	25,5°C
Outdoor Temp.	0,0°C
Operation Current	0A
Starting Delay	0sec

Icon	Description
Setting Temp.	It shows the set temperature for the current operation mode.
Outdoor Temp.	It shows the current outdoor air temperature value.
Operation Current	It shows the operation compressor's overall operation current value.
Starting Delay	It shows the time of the standby state before starting the product.

### Chiller control

Chiller control sets the Start/Stop, Set Temperature, Operation Mode (Only for Heatpump Model), Control Mode, and Max. Operating Frequency.

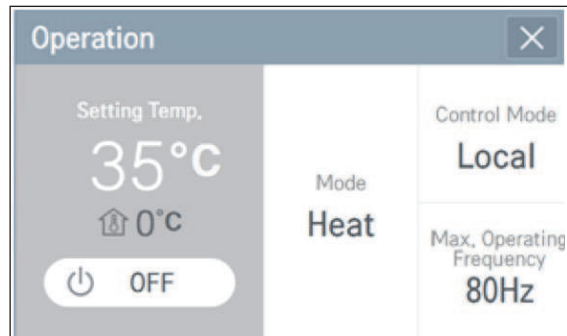

Icon	Description
ON	It selects the start and stop signal command of the product.
Setting Temp.	It sets the target temperature value for the current operation mode. (Cooling: 5.0~20.0 °C, heating: 30.0~55.0 °C)
ON	It sets the cooling/heating operation mode.
Control Mode Local	It selects the control mode of the signal command method for the product control.
Max. Operating Frequency 80Hz	Max. Operating Frequency is the feature to save the energy by limiting the operation capacity up to the frequency set by the user. (Setting Range : 70Hz ~ 130Hz) The standard set value for the Max. Operating Frequency is 120 Hz. The setting unit for the Max. Operating Frequency is 10 Hz.



- **ON/OFF**

When you touch the ON button, a popup window to select ON/OFF is displayed.

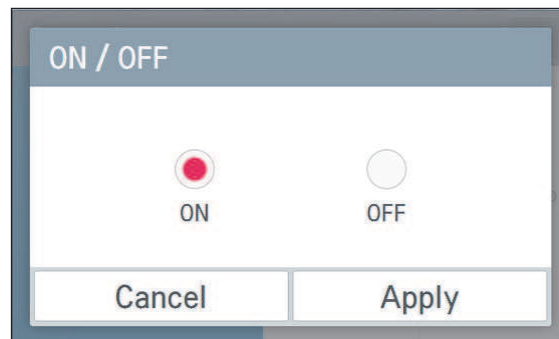

- **Setting temperature**

If you touch the area where the chiller control's set temperature is displayed, a popup window to input the setting temperature is displayed.

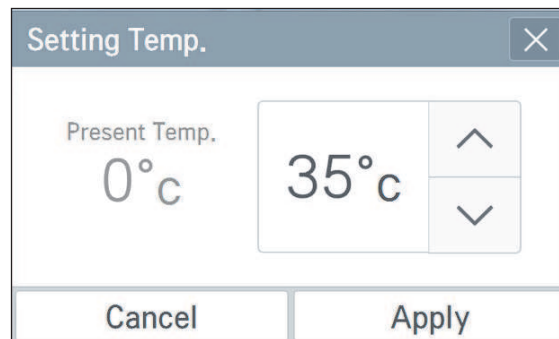

In the temperature setting popup window, you can change the temperature with up/down arrow input, and if you touch the temperature setting display area, you can input the setting temperature input with numeric keyboard.

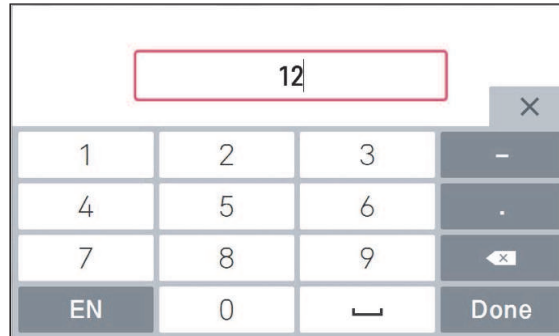

After changing the temperature setting, if you press Apply, the set value is reflected, and if you press Cancel, the previous setting is maintained.

- **Operation mode**

If you touch the chiller control's operation mode area, a popup window to set the operation mode is displayed.

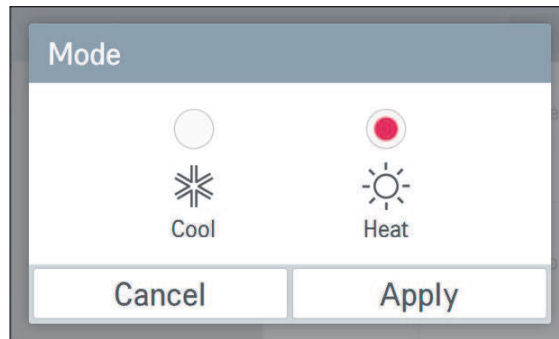



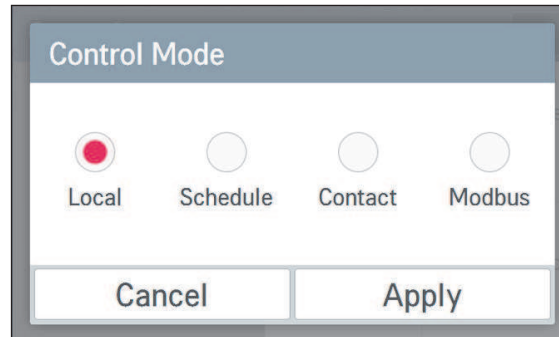

After changing the operation mode, if you press Apply, the set value is reflected, and if you press Cancel, the previous setting is maintained.

- **Control mode**

If you touch the chiller control's control mode area, a popup window to set the control mode is displayed.



After selecting the desired control mode, if you press Apply, the selected control mode is applied, and if you press Cancel, the previous setting is maintained.

Icon	Description
 Local	Manual control mode through HMI
 Schedule	If the schedule mode is set, manual and remote control are not possible, and only the start/stop by the schedule is possible.
 Contact	ON/OFF is only possible by the chiller controller's "Remote Start" signal.
 Modbus	ON/OFF is only possible by the external MODBUS communication.

**⚠ CAUTION**

If the product enters the modbus remote mode, all the information can only be monitored via HMI, and the actual operation of starting/stopping or changing the set temperature can only be done through the external controller.  
To make changes to control from HMI, change the control mode to "Local".

**⚠ CAUTION**

CH10009 remote communication error will occur when the communication is disconnected between the two controllers. When the communication is recovered, it will automatically resume. If the remote modbus connection is not used, reset the power of the main PCB of the unit to cancel the alarm.

The protocol details provided for modbus interlock of external device are as follows.

- Physical Layer : RS-485 Serial Line
- Mode : MODBUS RTU Mode
- Baud Rate : 9 600
- Parity : None Parity
- 1 Stop Bit
- Applied Function Code

Function Code	Sub Function	Function Name	Start Address form Master Device
0x01	None	Read Coil Register	Address-1
0x02	None	Read Discrete Input	Register Address-10001
0x03	None	Read Holding	Register Address-40001
0x04	None	Read Input	Register Address-30001
0x05	None	Write Single Coil	Register Address-1
0x06	None	Write Single Holding	Register Address-40001
0xF1~FF	Reserved for Exception Code		

Refer to the modbus protocol in the Appendix for the protocols provided.

- **Max. Operating Frequency**

If you touch the Max. Operating Frequency area, a popup window to input the Max. Operating Frequency is displayed.

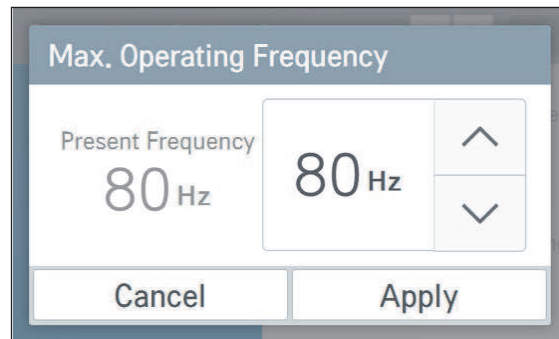





The Max. Operating Frequency can be adjusted by pressing Up/Down arrows in the popup window for the Max. Operating Frequency.

### Cycle information screen composition

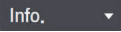
To enter the cycle information screen, press the cycle information button in Home screen.

Cycle #1	Info.
Cycle Info.	
4-Way Valve	OFF
Subcooling Bypass Valve	OFF
Inverter Comp #1	OFF
Inverter Comp #2	OFF

Icon	Description
	It shows the currently selected cycle.
	You can select the cycle information and the cycle temperature.
	It shows the status value of the 4-way valve during the cooling/heating switching. (It is the item that is displayed only in the cooling/heating combined model.)
	It shows the status of the over-cooling bypass valve.
	It shows the current operation status of No. 1 inverter compressor.
	It shows the current operation status of No. 2 inverter compressor.

Cycle #1		Info.
Cycle Info.		^
Comp. Frequency	0Hz	
EEV status	0pls	$\frac{2}{2}$
High Pressure	0kPa	
Low Pressure	0kPa	v

Icon	Description
Comp. Frequency	It shows the inverter compressor's operation frequency value.
EEV status	It shows the current EEV pulse signal value.
High Pressure	It shows the current high pressure value.
Low Pressure	It shows the current low pressure value.

- Cycle temperature

Cycle #1		Temp.
Cycle Temp.		
Load L,W	0.0°C	^
Sat. Condensing	0.0°C	1/2
Sat. Evaporating	0.0°C	
Liquid pipe	0.0°C	v

Icon	Description
Load L,W	It shows the corresponding cycle's load leaving water temperature value.
Sat. Condensing	It shows the corresponding cycle's saturated condensing temperature value.
Sat. Evaporating	It shows the corresponding cycle's evaporation temperature value.
Liquid pipe	It shows the corresponding cycle's liquid pipe temperature value.



Cycle #1	Temp.	
Cycle Temp.		
HEX.	0.0°C	^
Suction	0.0°C	2/2
Comp. #1 Discharge	0.0°C	
Comp. #2 Discharge	0.0°C	v

Icon	Description
HEX.	It shows the cycle's HEX temperature value.
Suction	It shows the corresponding cycle compressor's average suction temperature value.
Comp. #1 Discharge	It shows the inverter compressor No. 1 compressor's discharge temperature value.
Comp. #2 Discharge	It shows the inverter compressor No. 2 compressor's discharge temperature value.

## Introduction to schedule menu

This chapter describes the schedule menu and screen composition that you need to know to operate the schedule of the product.

### View schedule screen

In Home screen, if you press the schedule icon, the schedule screen appears.

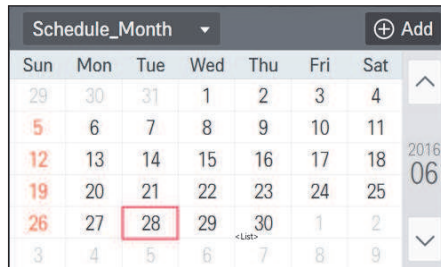

<Month>

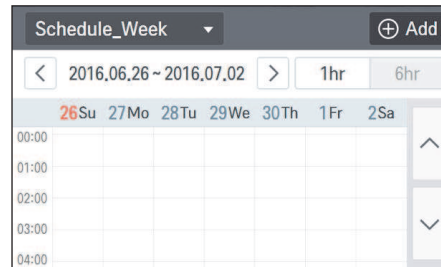

<Week>

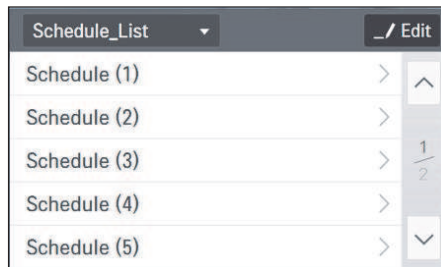

<List>

Icon	Description
	You can check the monthly set schedule at a glance.
	You can check the start time of the schedule and the set operation mode.
	You can check the set schedule in a list.

- Add schedule

1. In the schedule viewing screen, press **Schedule\_Month** button at the top right side.

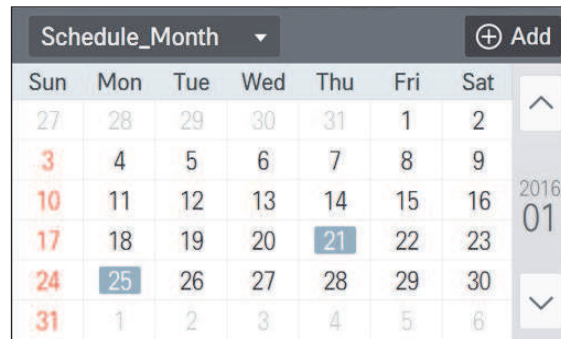

2. As follows, when Add screen appears, input the basic schedule information.

Add	
Phase1. Input basic schedule information.	
Name (50) Schedule (8)	Period 2016.06.28 ~ 2066.06.28
Time AM 12:00	Repeat Everyday

① When you press the name area, a popup window to input the schedule name is displayed. Input the name to use, and press Apply button. If Cancel button is pressed, the previous setting is maintained.

Name Setting(50 Letter)	
Schedule (8)	
Cancel	Apply

- ② When you press the date area, a popup window to set the date is displayed. Set the start date and end date to use the schedule operation, and press Apply button. If Cancel button is pressed, the previous setting is maintained.

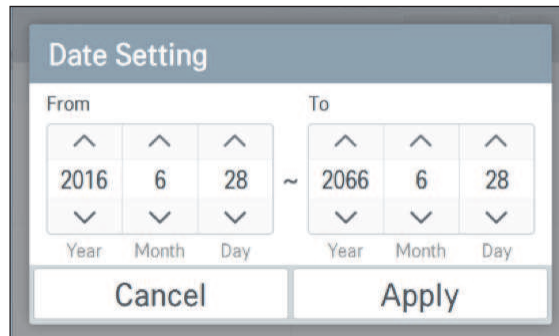

The 'Date Setting' popup window is titled 'Date Setting' and is divided into two main sections: 'From' and 'To'. Each section contains three columns of date pickers for Year, Month, and Day. The 'From' section shows '2016', '6', and '28' respectively, with 'Year', 'Month', and 'Day' labels below. The 'To' section shows '2066', '6', and '28' respectively, also with 'Year', 'Month', and 'Day' labels below. A tilde '~' symbol is placed between the two date sections. At the bottom of the window are two buttons: 'Cancel' on the left and 'Apply' on the right.

- ③ When you press the time area, a popup window to set the time is displayed. Set the time to use the schedule operation, and press Apply button. If Cancel button is pressed, the previous setting is maintained.

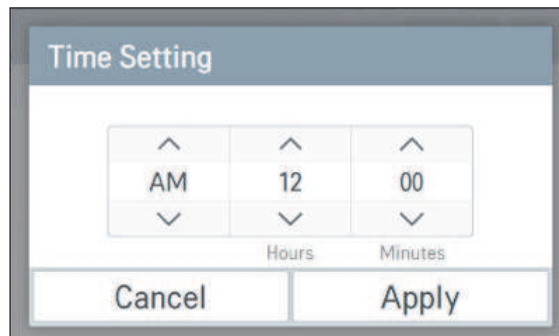

The 'Time Setting' popup window is titled 'Time Setting' and features three columns of time pickers. The first column shows 'AM', the second shows '12', and the third shows '00'. Below the '12' and '00' pickers are the labels 'Hours' and 'Minutes' respectively. At the bottom of the window are two buttons: 'Cancel' on the left and 'Apply' on the right.

- ④ When you press the day of week selection area, a popup window to select day of week is displayed. Select the day of week to use the schedule operation, and press Apply button. If Cancel button is pressed, the previous setting is maintained.

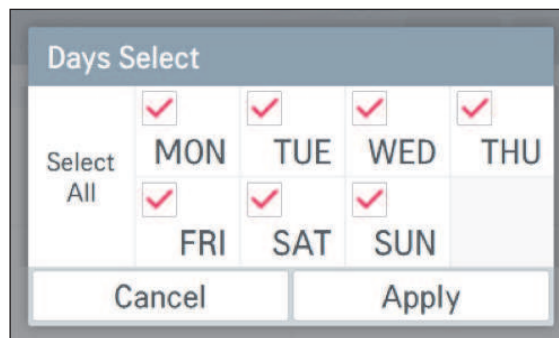

The 'Days Select' popup window is titled 'Days Select' and displays a grid of days of the week. The days are arranged in two rows: 'MON', 'TUE', 'WED', 'THU' in the top row, and 'FRI', 'SAT', 'SUN' in the bottom row. Each day has a red checkmark in a small box above it. To the left of the grid is a 'Select All' option with a red checkmark. At the bottom of the window are two buttons: 'Cancel' on the left and 'Apply' on the right.

3. After the input of the basic information, if you press **Next** button, a screen to set the detail information is displayed.

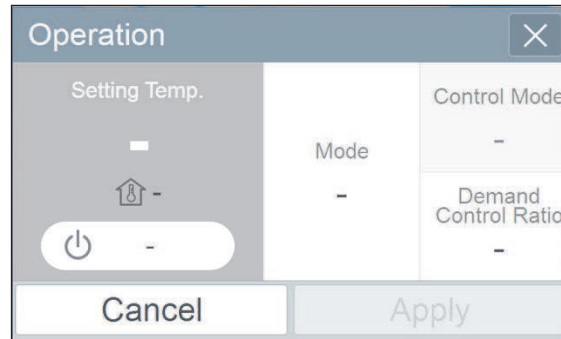

- ① When you press the mode area, a popup window to select the mode is displayed. Select the operation mode to use the schedule operation, and press Apply button. If Cancel is pressed, the previous setting is maintained.

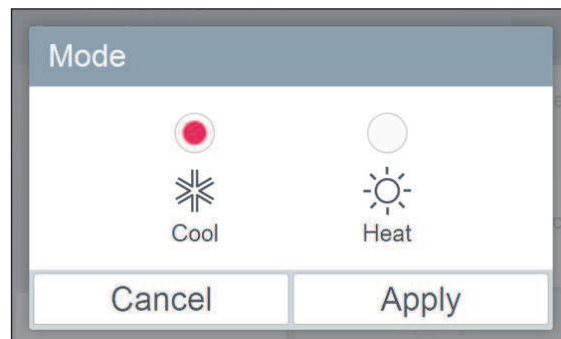

- ② When you press the area where the set temperature is displayed, a popup window to input the temperature setting is displayed. Set the temperature to use, and press Apply button. If Cancel is pressed, the previous setting is maintained.

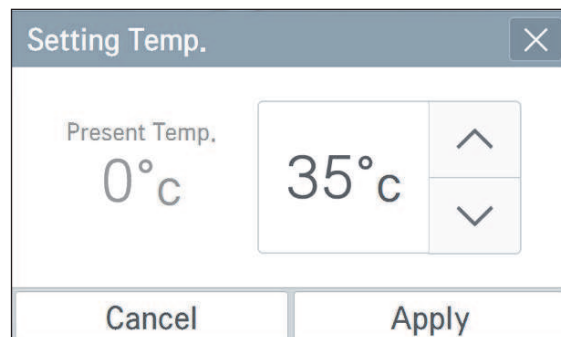

- ③ When you press the ON/OFF button, a popup window to select ON/OFF is displayed. Decide whether to ON or OFF the schedule operation to use, press the button to use, and press Apply button. If Cancel is pressed, the previous setting is maintained.

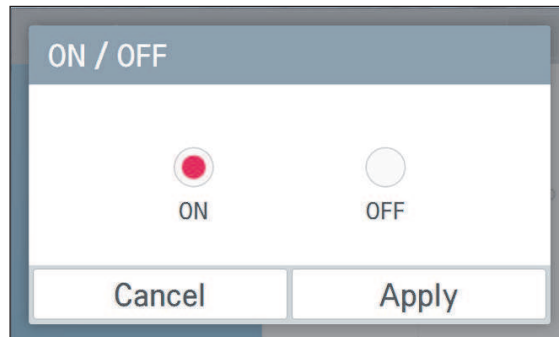

- ④ When the Max. Operating Frequency are is touched, the popup window to enter the Max. Operating Frequency opens. After selecting a value to set, press Apply button. If cancel is pressed, the previous setting is remained.

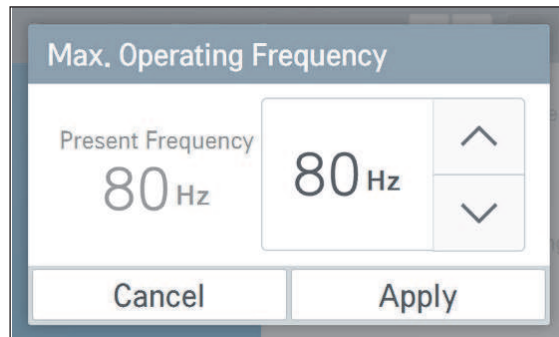

4. After the input of all detail information, when you press Apply button of the chiller control, the schedule addition is completed. If Cancel is pressed, the previous setting is maintained.

Operation			
Setting Temp.	5°C	Control Mode	-
Mode	Cool	Demand-Control Ratio	-
ON			
Cancel		Apply	

• Edit schedule

1. In View schedule \_ List screen, select the schedule to edit.

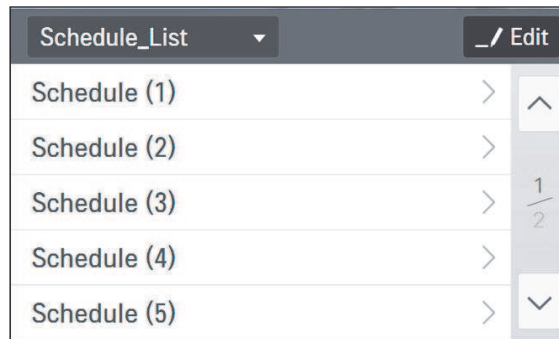

2. When the popup window of the selected schedule is displayed, press the button to work.

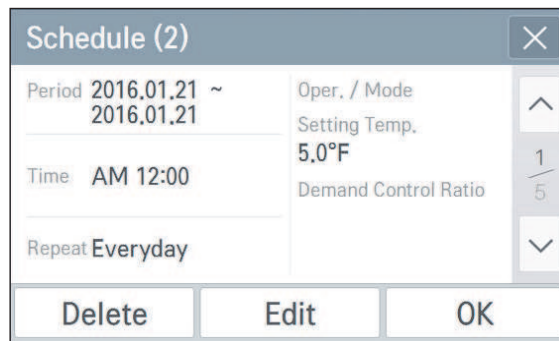

Icon	Description
	Popup window saying "Do you want to delete the selected schedule?" is displayed, and when you press Apply button, it is deleted from the list.
	A popup window to edit is displayed, and set with the same method as the schedule addition.
	It maintains the current setting, and the popup window disappears.



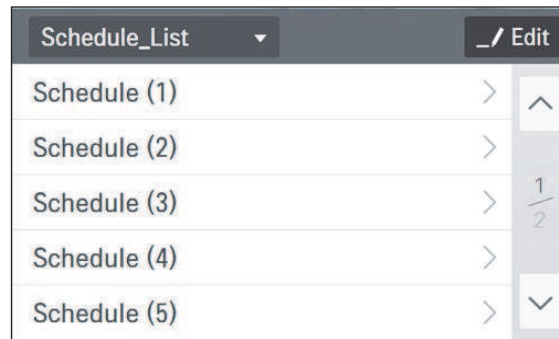

- Schedule list edit

1. In View schedule \_ List screen, press  button at the top right side.

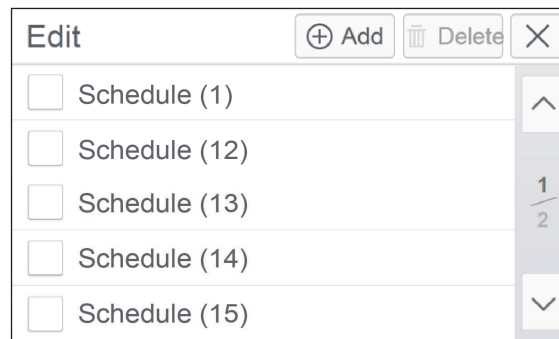

2. When the screen to edit the list appears, carry out the schedule addition and list deletion work.



Icon	Description
	When Add button is pressed, it moves to the schedule addition screen.
	When you select a list to delete, Delete button is activated, and when you press Delete button, the selected list is deleted.

## Introduction to record menu

This chapter describes how to check the record of the events that triggers the alarm.

- **Error screen composition**

The occurred error history is stored in the order of the occurred time, and according to the selection, you can check for day, week, and month.

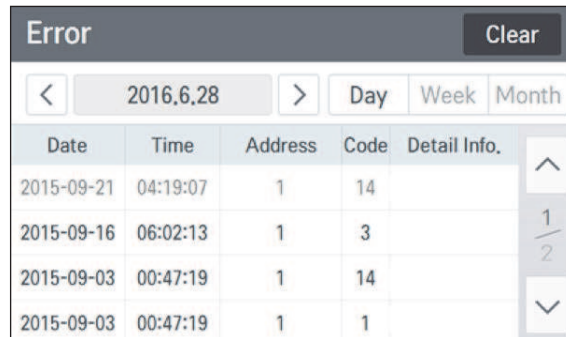

The screenshot shows the 'Error' screen with a 'Clear' button in the top right. Below the title bar, there are navigation arrows, a date field showing '2016.6.28', and filter buttons for 'Day', 'Week', and 'Month'. The main area contains a table with columns: Date, Time, Address, Code, and Detail Info. The table lists four error records. On the right side of the table, there are up and down arrow buttons and a page indicator showing '1/2'.

Date	Time	Address	Code	Detail Info.
2015-09-21	04:19:07	1	14	
2015-09-16	06:02:13	1	3	
2015-09-03	00:47:19	1	14	
2015-09-03	00:47:19	1	1	

- **View detail information**

When you select a history to view in detail, detail information popup window is displayed. It shows the error occurrence date, time, address, code, and the information of the error code. When you press Confirm, the popup window disappears.

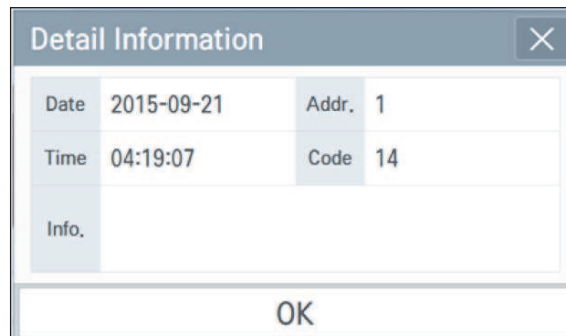

The screenshot shows a 'Detail Information' popup window with a close button (X) in the top right. The window contains a table with the following data:

Date	2015-09-21	Addr.	1
Time	04:19:07	Code	14
Info.			

At the bottom of the popup window, there is an 'OK' button.

- **Delete history**

When you press **Clear** button at the top right side of Error screen, a popup window to input password is displayed.

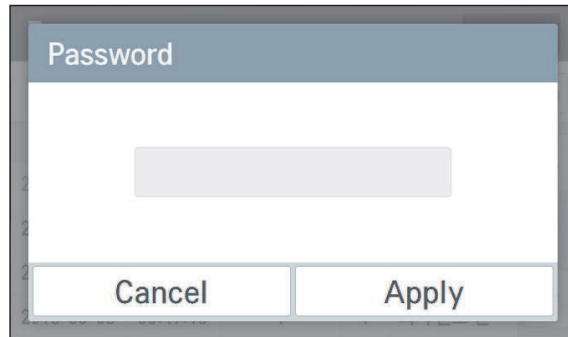

A screenshot of a 'Password' dialog box. The title bar is dark blue with the word 'Password' in white. Below the title bar is a large, empty, light gray rectangular input field. At the bottom of the dialog box, there are two buttons: 'Cancel' on the left and 'Apply' on the right, both with black text on a light gray background.

Input the password, and when you press Apply button, all error histories will be deleted.

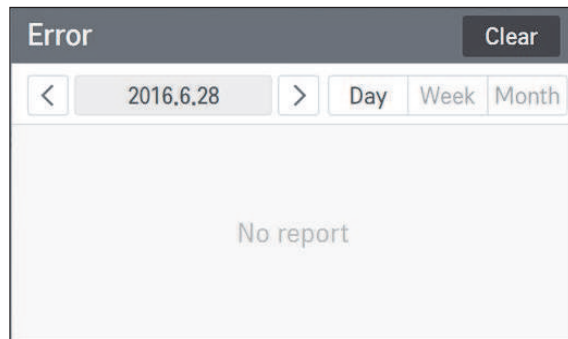

A screenshot of the 'Error' screen. The title bar is dark gray with the word 'Error' in white. In the top right corner of the title bar is a 'Clear' button. Below the title bar, there is a navigation bar with a left arrow, a date field showing '2016.6.28', a right arrow, and three radio buttons labeled 'Day', 'Week', and 'Month'. The main content area is light gray and contains the text 'No report' centered.

\* The clear function is for the service, and the password will not be provided to the customers.

## View setting menu

This chapter describes the setting menu's screen and the setting method required for the operation of the product.

### Setting screen composition

In Home screen, if you press Setting button, after password input, it enters Setting screen, and the following screen appears. (Initial password: digital21)

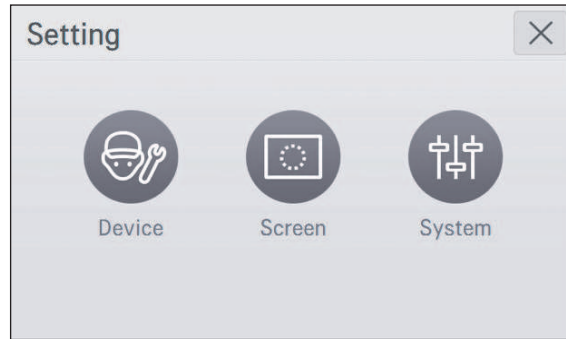

### Device

In the setting screen, when you press the device icon, device screen appears.

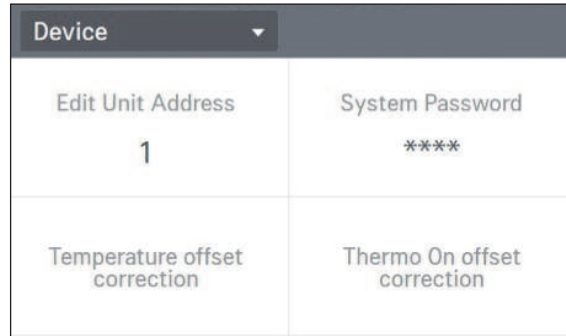

Icon	Description
Edit Unit Address	It sets chiller address and count of chiller units. Initial chiller address and count of chillers is 1. For automatic control (or ACP), MODBUS communication, and HMI interface, if chiller main PCB address is changed, HMI chiller address setting value shall be set as the same as main controller.
System Password	It selects whether to change and use password. (Initial password : digital21)
Common water out temperature offset correction	It is a function for the service and it is restricted.
Thermo On offset correction value	It is a function for the service and it is restricted.

- **Edit Unit Address**

In the device mode, if you press Edit Unit Address area, the Edit Unit Address window is displayed.

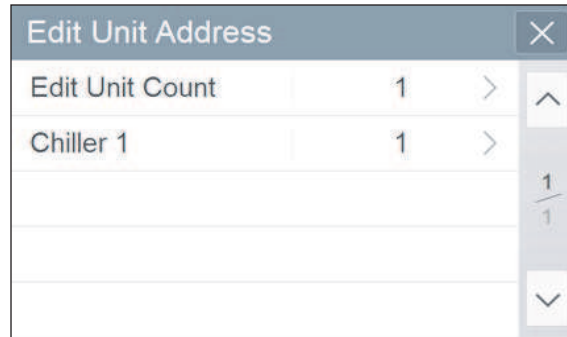

If you press Edit Unit Count area, a window to set count of chillers appears. Select from 1 to 5, Count of chillers to interface, and press Apply button. If Cancel is pressed, the previous setting is maintained.

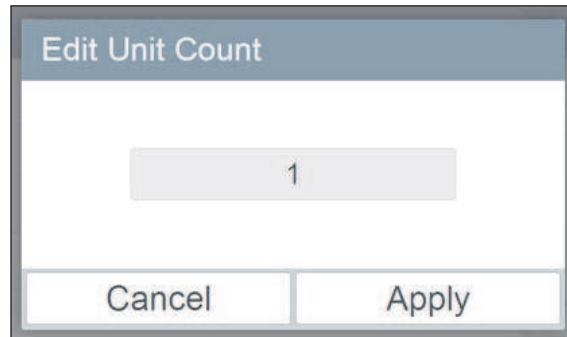

\* Default value is 1, and you can set and use up to 5.

\* Setting product address The product address must be in both main PCB of unit and HMI.  
If the two addresses are not the same, there will be an error in HMI communication.

**CAUTION**

If you reset the address in HMI while the product is operating, it will cause a communication error and stop the product. Always reset the address after the product has stopped completely.

In Edit unit Address, if you press chiller 1 area, Edit Unit Address window appears. Input the desired address and press Apply button. If Cancel is pressed, the previous setting is maintained.

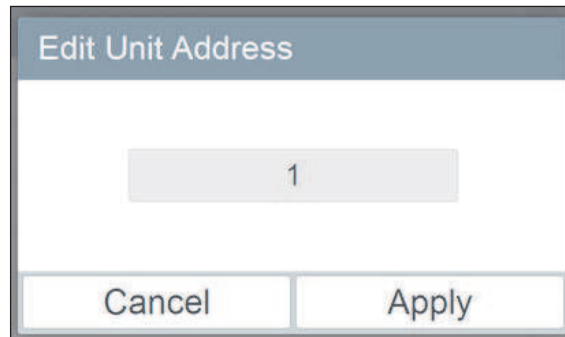

\* If you select 2 or more unit count, you need to input address for each unit.

- **Password setting**

In the device mode, if you press System Password area, Password window is displayed.

1. Do not use password

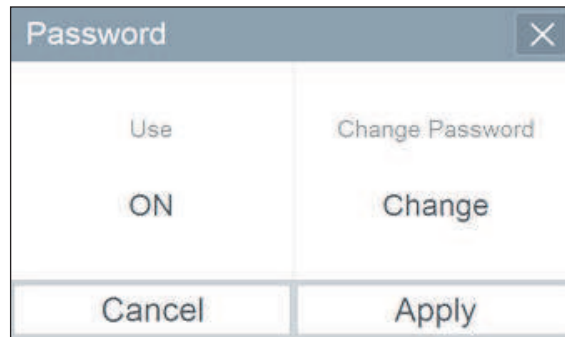

- ① If you press Use ON area, it is changed to Use OFF.



- ② Select Apply. If Cancel is pressed, the previous setting is maintained.

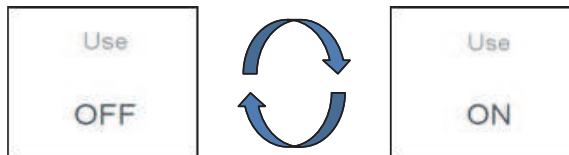

\* Default is Use, and if you want to use again, you can press Use OFF, input password, and press Apply. (Initial password: digital21)

## 2. Password change

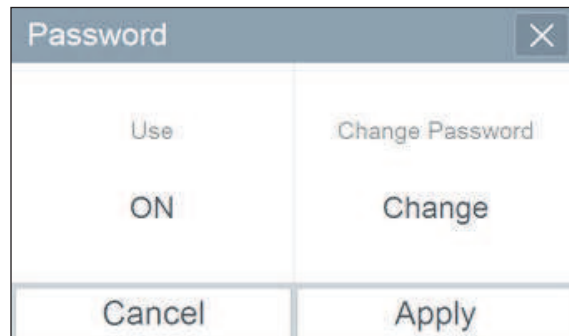

- ① If you press Chang Password area, Change Password window appears.

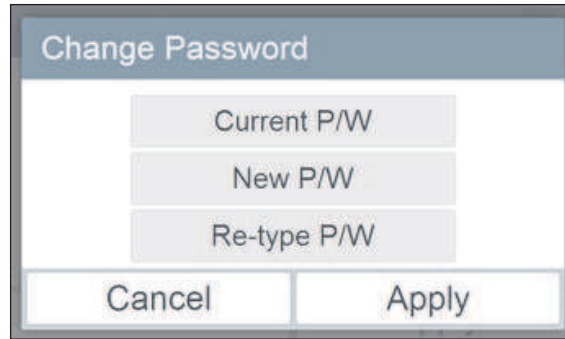

The image shows a 'Change Password' dialog box. It has a title bar with the text 'Change Password'. Below the title bar, there are three input fields labeled 'Current P/W', 'New P/W', and 'Re-type P/W'. At the bottom of the dialog box, there are two buttons: 'Cancel' on the left and 'Apply' on the right.

- ② Input Current P/W, New P/W, and Re-type P/W, and press Apply button.

\* If you input wrong password for 5, it check whether to initialize the password. If you press Cancel button, password input screen appears again. For password initialization, please contact installation store or service center.

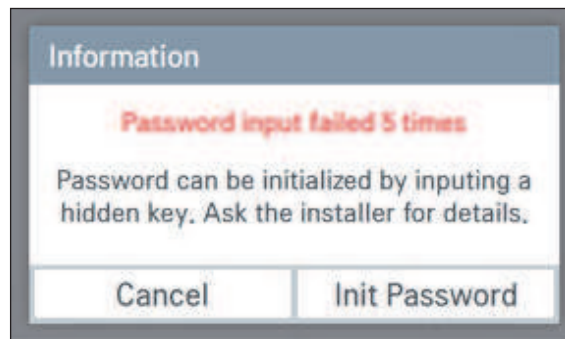



The image shows an 'Information' dialog box. It has a title bar with the text 'Information'. Below the title bar, there is a red warning message: 'Password input failed 5 times'. Below this message, there is a text block: 'Password can be initialized by inputting a hidden key. Ask the installer for details.' At the bottom of the dialog box, there are two buttons: 'Cancel' on the left and 'Init Password' on the right.

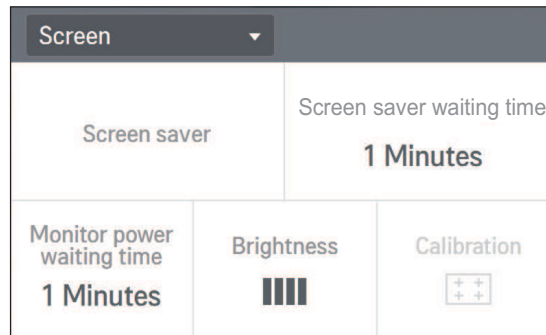

## Screen

In the setting screen, when you press the screen icon, Screen appears.

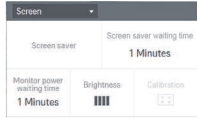

Icon	Description
	Select whether to use the screen saver.
Screen saver waiting time <b>1 Minutes</b>	It sets the waiting time to display the screen saver.
Monitor power waiting time <b>1 Minutes</b>	It sets the time to change to the minimum brightness of the screen when there is no touch input.
Brightness 	It adjusts the screen brightness according to the ambient illumination intensity.

- **Screen saver**

When you press the screen saver area, the screen saver window is displayed.

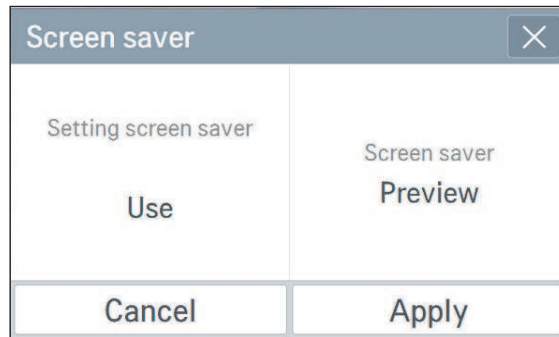

- ① Press the area indicating whether to use the screen saver. Whenever you press the area, the selected value is changed.

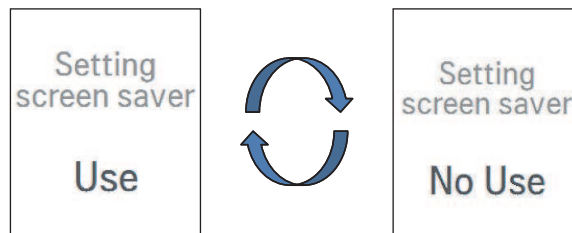

- ② When whether to use the screen saver is selected as Use, the screen saver preview is activated, and when you press the activated area, you can see the set screen saver in advance.

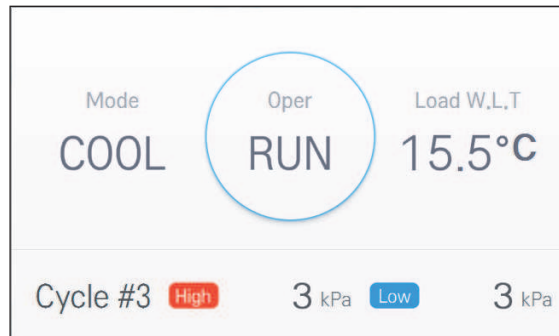

- ③ When you press Apply button of the screen saver, the selected setting is applied, and if Cancel is pressed, the previous setting is maintained.

- **Screen saver waiting time**

When you press the screen saver standby area, the screen saver standby window is displayed.

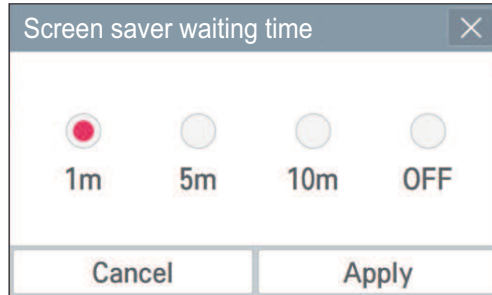

After selecting the time to apply, press Apply button. If Cancel is pressed, the previous setting is maintained.

- **Monitor power off**

When you press the screen power saving area, the screen power saving window is displayed.

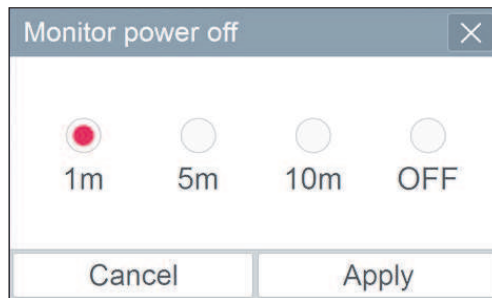

After selecting the time to apply, press Apply button. If Cancel is pressed, the previous setting is maintained.

- **Brightness**

When you press the screen brightness area, the screen brightness window is displayed.

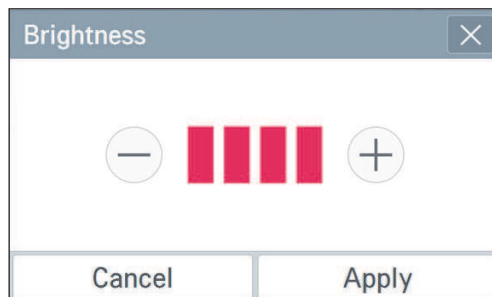

After setting the desired brightness by pressing the – and + button at the left/right, press Apply button. If Cancel is pressed, the previous setting is maintained. The screen brightness can be selected among 25 %, 50 %, 75 %, and 100 %.

**System (Normal)**

When you press the system icon, System screen appears. System is divided to normal and advance.

System		Normal
Date	Time	Controller name
2016.06.28	PM 07:27	Scroll Chiller
Speaker	Temperature display	Language
OFF	°F	English

Icon	Description
Date 2016.06.28	It is the base value of the date recognized by the product, and the date display and the schedule interface date, etc. are operated based on the set date.
Time PM 07:27	It is the base value of the time recognized by the product, and the time display and the schedule interface time, etc. are operated based on the set time.
Controller name Scroll Chiller	Input and edit the controller's name, and the applied name is displayed at the top left side of Home screen.
Speaker OFF	It selects whether to use the touch sound.
Temperature display °F	It selects the unit of the temperature to be displayed on the controller. (°C or °F can be selected)
Language English	It selects the language displayed on the controller. (Korean or English can be selected)

- **Date**

In the System, when you press the date area, a window to set the date is displayed.

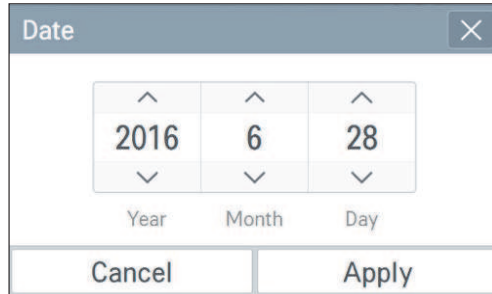

The image shows a 'Date' dialog box with a close button (X) in the top right corner. It contains three columns of spinners for Year, Month, and Day. The Year spinner is set to 2016, the Month spinner to 6, and the Day spinner to 28. Below the spinners are labels 'Year', 'Month', and 'Day'. At the bottom of the dialog are two buttons: 'Cancel' and 'Apply'.

After selecting the date to set by pressing up/down button, press Apply button. If Cancel is pressed, the previous setting is maintained.

- **Time**

In the System, when you press the time area, a window to set the time is displayed.

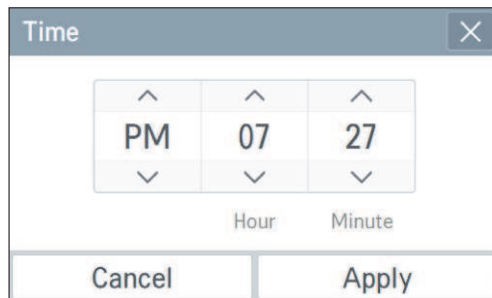

The image shows a 'Time' dialog box with a close button (X) in the top right corner. It contains three columns of spinners for AM/PM, Hour, and Minute. The AM/PM spinner is set to PM, the Hour spinner to 07, and the Minute spinner to 27. Below the spinners are labels 'Hour' and 'Minute'. At the bottom of the dialog are two buttons: 'Cancel' and 'Apply'.

After selecting the time to set by pressing up/down button, press Apply button. If Cancel is pressed, the previous setting is maintained.

- **Controller name edit**

In the System, when you press the controller name edit area, a window to edit the controller name is displayed.

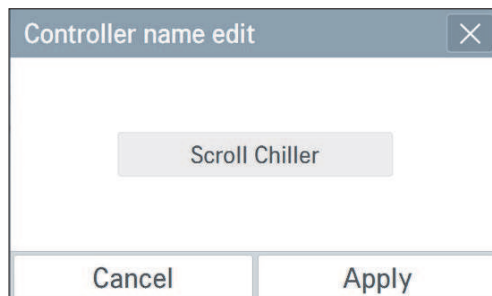

The image shows a 'Controller name edit' dialog box with a close button (X) in the top right corner. It contains a text input field with the text 'Scroll Chiller'. At the bottom of the dialog are two buttons: 'Cancel' and 'Apply'.

After the input of the desired name, press Apply button. If Cancel is pressed, the previous setting is maintained.

- **Speaker**

In the System, whenever you press the touch speaker area, it toggles between Use and Do not use. There is no separate Apply button.

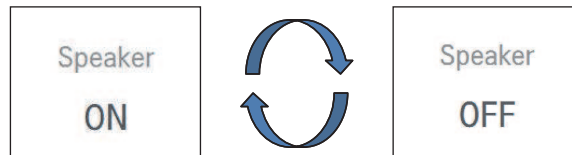

- **Temperature unit**

In the System, when you press the temperature unit area, a window to change the temperature unit is displayed.

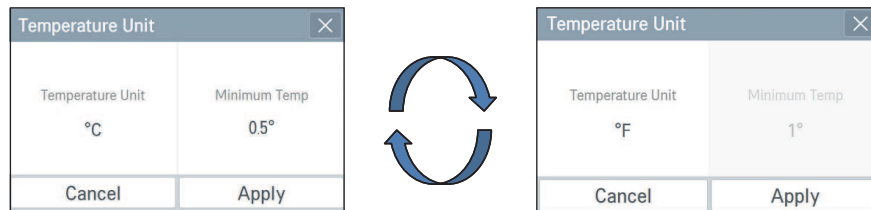

In the screen, when you press temperature unit area, the temperature unit is changed. In Celsius unit, the minimum temperature unit can be selected between 1 °C and 0.5 °C. When you press Apply, the setting is applied, and if Cancel is pressed, the previous setting is maintained.

- **Language**

In the System, when you press language setting area, the window to set the language is displayed.

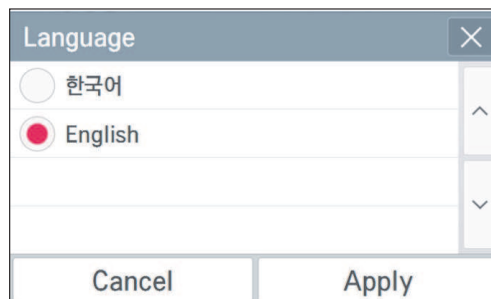

Select the desired language, and press Apply button. If Cancel is pressed, the previous setting is maintained.

**System(Advance)**

When you press the system icon, the System normal screen is displayed, and when you set Advance, the following screen appears.

System	Advance
Version information <b>Ver.1.00.3</b>	Operating hours <b>1 hours</b> <input type="button" value="Clear"/>
<b>Open Source License</b>	

Icon	Description
Version information <b>Ver.1.00.3</b>	It shows the software version of the controller.
<b>Open Source License</b>	It shows the contents of the open source
Operating hours <b>1 hours</b> <input type="button" value="Clear"/>	It shows the overall operation time of the product. The clear function is for the service, and the customer usage is restricted.

- **Version information**

In the System advance screen, when you press Version information area, a popup window to check the version information is displayed.

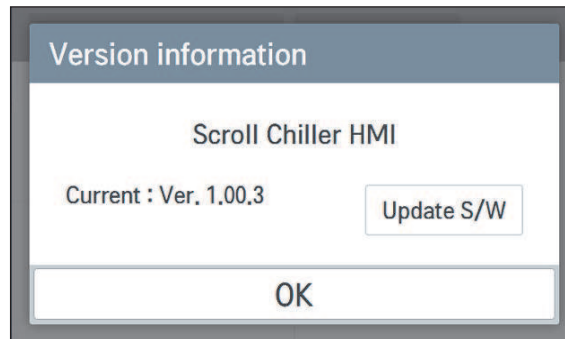

Check the current version, and when you press OK button, the popup window disappears.

- **Open source license**

In the System advance screen, when you press Open source license area, you can check the contents of Open source license.

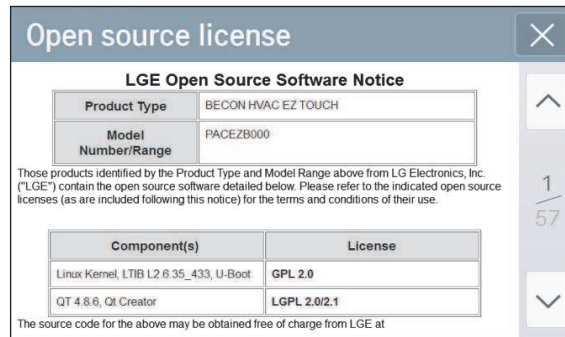

※ The clear function is for the service, and the password will not be provided to the customers.



### Chiller interface control

This chapter describes about HMI's product interface control.

HMI can control interface to up to 5 products, and you can control and monitor up to 5 products as if it is 1 product. In Device screen, when you enter Edit Unit Address setting, you can set Count of unit and address. For detail setting method, please refer to "Edit Unit Address".

#### • Unit information

If you press left/right direction button , you can check each interfaced chiller information.

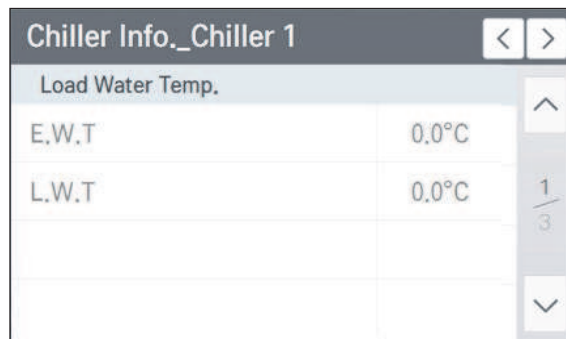

Chiller Info_Chiller 1		< >
Load Water Temp.		^
E.W.T	0.0°C	1/3
L.W.T	0.0°C	
		v

#### • Operation

In Chiller Operation\_Total, you can set the same operation condition for all the chillers.

For individual control, you can press left/right direction button  for individual control.

But, in individual control, you cannot change Control Mode or Run Mode.

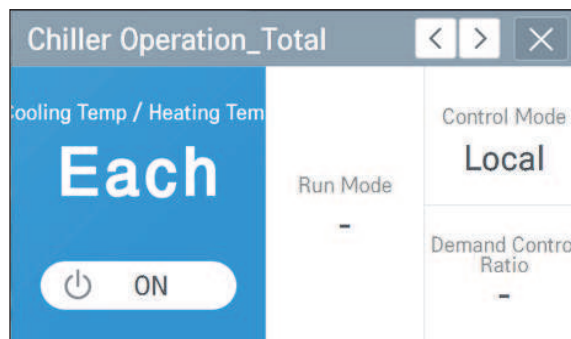

Chiller Operation_Total			< > X
Cooling Temp / Heating Temp	Run Mode	Control Mode	-
<b>Each</b>	-	<b>Local</b>	
 ON		Demand Control Ratio	-

- **Cycle information**

If you press left/right direction button , you can check each of cycle information and temperature of interfaced chillers.

Cycle #1	Cycle Info.	<	>
Cycle Info._Chiller 1			
Four Way Valve	ON	^	
Bypass Valve	OFF	1/3	
Inverter Comp. #1	OFF		
Inverter Comp. #2	OFF	v	

- **Error**

You can check entire history \_ error of the interfaced chillers.

Error					Clear		
<		2016.6.28	>		Day	Week	Month
Date	Time	Address	Code	Detail Info.			
2015-09-21	04:19:07	1	14		^		
2015-09-16	06:02:13	1	3		1/2		
2015-09-03	00:47:19	1	14				
2015-09-03	00:47:19	1	1		v		

\* Individual schedule and setting are not supported.

# FROM INSTALLATION TO TEST RUN

## Flowchart from installation to test run

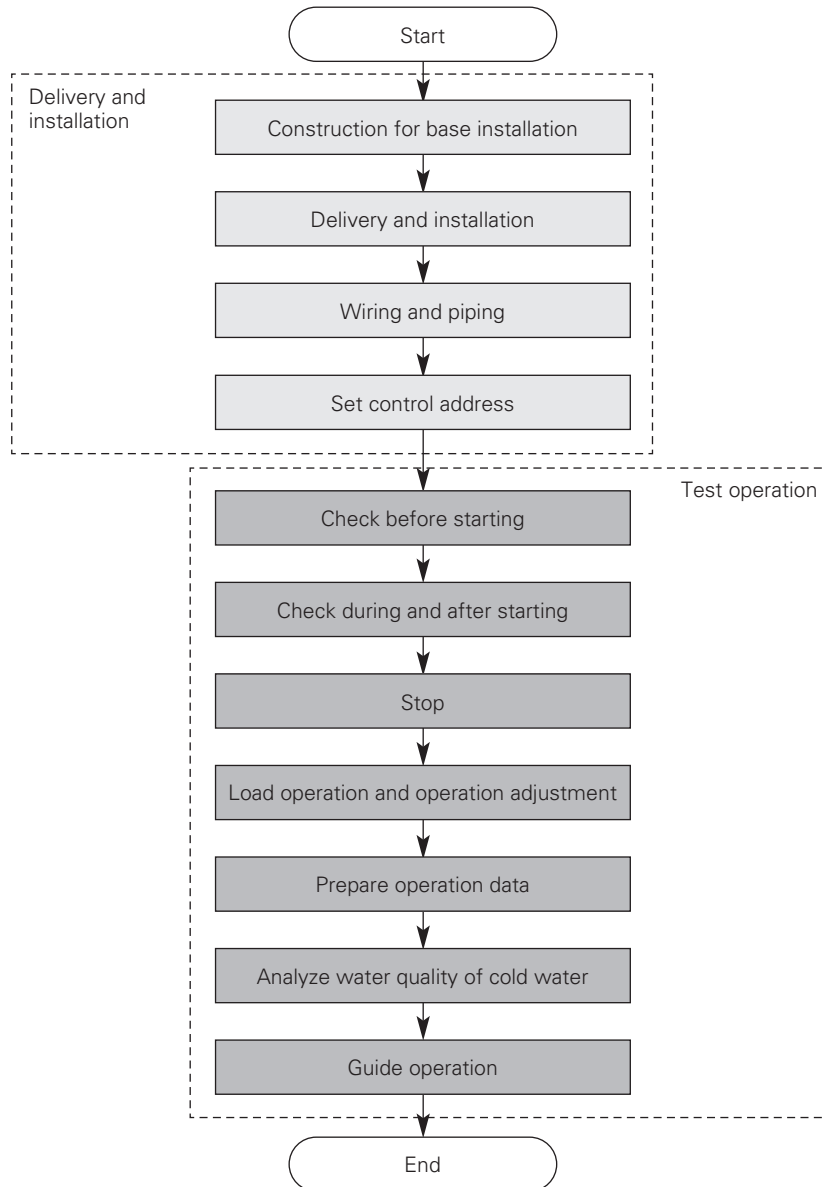

## INSTALLATION

### Selecting installation location

Because the user operating the product varies based on the mode setting item of the user setting, set up and operate the product as shown below.

#### Details to consider when selecting the installation location

Select the location that fits the following conditions to install the product.

- Location without direct heat from other heat source
- Location where noise of the chiller does not have negative impact to the neighbors
- Check the installation direction of the unit for the seasonal wind during the winter. Install the product so that the seasonal wind does not affect only one side of the product.
- Location not exposed to strong winds
- Location that can support the weight of the chiller
- Location with space for air flow and service
- Install the boundary sign, danger sign or barricade, if necessary.
- It is recommended to install a fence around chiller so that people or animals will not be able to access the area.
- When installing the product in areas with high humidity during the winter (Coast, seaside, lakeside), install the product where it is well ventilated and has plenty of exposure to sunlight. (Ex: Roof top with sunlight)
- If the product does not run during the winter, establish a plan to use the anti-freeze for the water supply.
- To prevent the condensed water from flowing, insulate the connected evaporator and pipe.
- To smoothly drain the condensed water, establish an inclined structure.
- Avoid installing the product at locations with the following conditions.
  - Location with corrosive gas such as acid or alkali gas. (Coolant can leak from the corroded pipes.)
  - Location with electromagnetic wave. (It can cause the product to malfunction from defective parts.)
  - Location where flammable gas is generated or flows to prevent fire.
  - Location with high level of carbon fiber or dust
  - Special location exposed to oil, steam or emulsified gas

#### Precaution for seasonal wind and winter season

In areas with heavy snow or in extremely cold areas, sufficient planning is required for the product to run smoothly.

Even in other areas, planning is required for seasonal wind during the winter season.

- Snow can go into the air discharge outlet of the condenser to freeze inside the chiller. Therefore install a large cover over the chiller for areas with heavy snowfall to prevent the snow from accumulating on the top.

- The chiller can freeze inside when the air inlet is clogged with snow. Therefore install the chiller on the base with at least twice the height of the average snow accumulation. (Default height of base: 300 mm)
- If there is more than 100 mm of snow on top of the chiller, always operate the unit after cleaning the snow.
- Do not install the product where there could be negative impact from snow in areas with heavy snowfall. Decide the installation direction of the chiller so that the side of the air heat exchanger does not face the direction of the snow. (Make the side of the air heat exchanger parallel to the direction of the snowfall.) Install a blocker with the height of the snow accumulation to avoid the snow around the chiller from being sucked into the coil side. (Prepare on site)
- If the wind comes in one direction of the unit where the seasonal wind is strong, there is a high chance that it can lead to issue with product capacity or imbalance of load. Therefore install the product so that it has consistent effect on the product cycle. If that is not possible, consider using a wind blocker or other devices. In areas with strong seasonal wind during the winter, apply the wind blocker hood, especially near the coastal area, without blocking the suction inlet of the chiller considering the direction of the wind. If the chiller is directly exposed to the seasonal wind during the winter, separately install a wind baffle. (Prepare on site)

**! WARNING**

- Regulation for refrigerant leakage  
: the amount of refrigerant leakage should satisfy the following equation for human safety.

$\frac{\text{Total amount of refrigerant in the system}}{\text{Volume of the room at which Indoor Unit of the least capacity is installed}} \leq 0.44 \text{ kg/m}^3$	$(0.028 \text{ lbs/ft}^3)$
---	----------------------------

**If the above equation can not be satisfied, then follow the following steps.**

- Selection of air conditioning system: select one of the next
  - Installation of effective opening part
  - Reconfirmation of Outdoor Unit capacity and piping length
  - Reduction of the amount of refrigerant
  - Installation of 2 or more security device (alarm for gas leakage)
- Change Indoor Unit type  
: installation position should be over 2 m (6.6 ft) from the floor (Wall mounted type → Cassette type)
- Adoption of ventilation system  
: choose ordinary ventilation system or building ventilation system
- Limitation in piping work  
: Prepare for earthquake and thermal stress

### Details to consider when installing on the coast

#### ⚠ CAUTION

- When installing the chiller near the coast, make sure that it is not directly exposed to the coastal wind.
- When installing the chiller directly exposed to the coastal wind, separate anti-corrosive treatment must be done on the condenser of the chiller.

\* Selecting location of chiller

Install the chiller where the building can block the coastal wind.

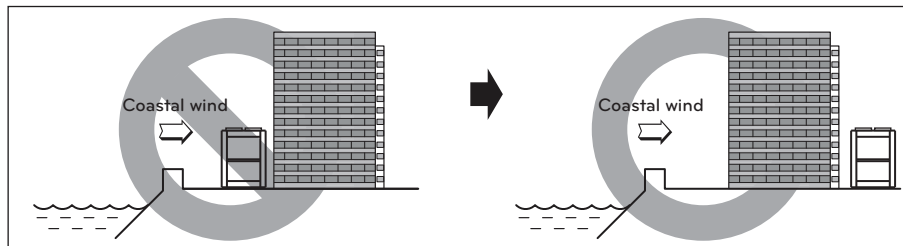

If the product has to be installed inevitably facing the coast, install a wall around the outdoor unit.

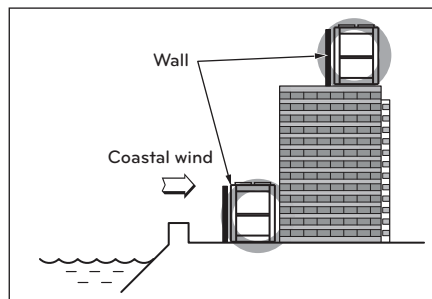

The wall must be made of sufficiently strong material such as concrete to block the coastal wind and must be 1.5 times larger than the size of the product to protect the product 1 000 mm apart. There must be 1 000 mm of clearance between the wall and the chiller for smooth circulation of air.

Install the product where the drainage is smooth.

**Basic installation space**

When installing the product, secure minimum space as shown below considering the service, suction and discharge of air flow.

\* Consider the ventilation condition.  
The air cooled chiller must be installed on open space or must have appropriate ventilation.  
When installed along the wall, there must be sufficient space for ventilation.

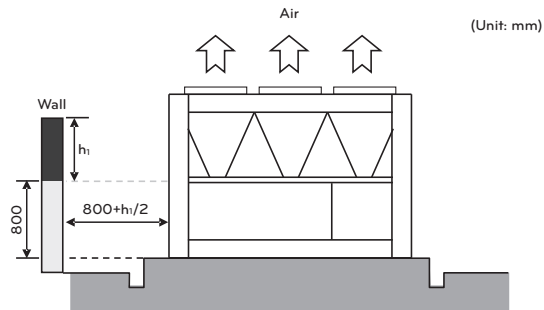

**Reference**  
If the side of the chiller is near the wall and the height of the wall is less than 800 mm, the distance between the wall and the chiller must be at least 800 mm. If the side of the chiller is near the wall and the wall is 800 mm or higher, space of half of h1 must additionally be secured on top of the 800 mm for the distance between the wall and the chiller.

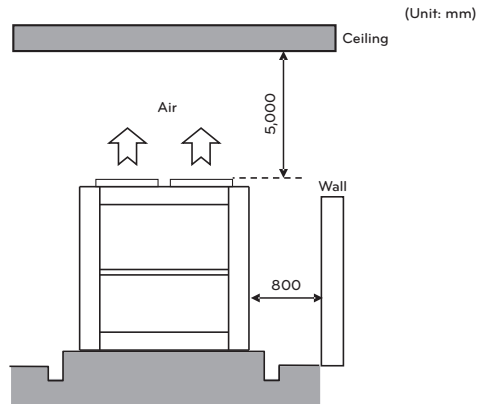

**Reference**  
If there is a ceiling on the top part of the chiller, the distance from the chiller to the ceiling must be 5 000 mm or above.  
If the front or rear side of the chiller is close to the wall, the distance from the wall to the chiller must be 800 mm or above.

**Consider the service space.**

There must be sufficient space for maintenance and repair work around the chiller.

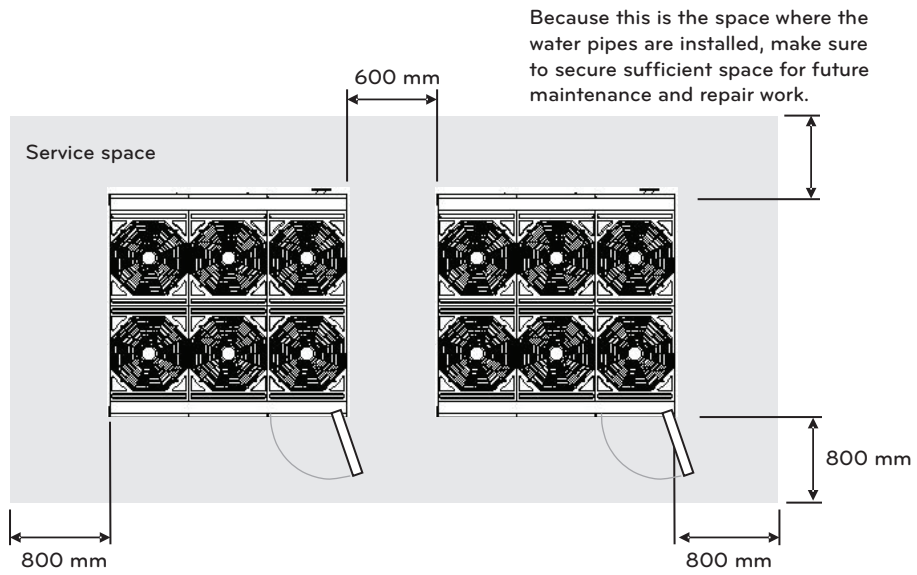
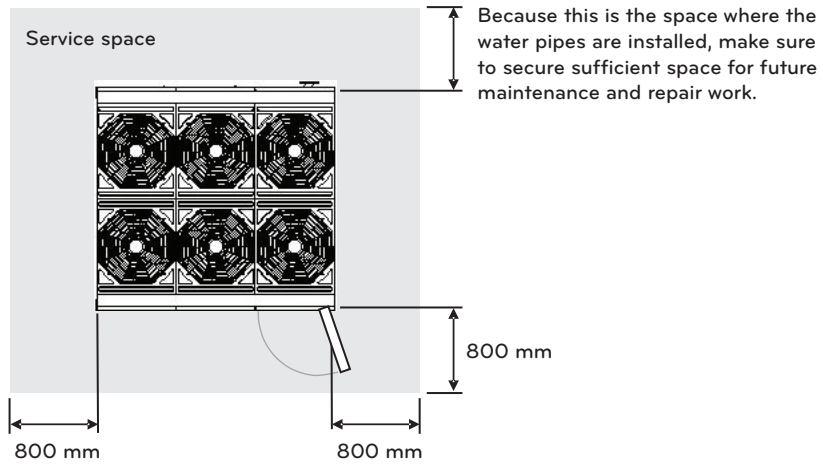



**Details to consider when installing the base**

- The base must be able to withstand concentrated load.
- The base must be installed with maximum gradient of 1/300.
- The height of the base must be higher than the surface of the water and drain holes must be installed around.
- Set the height of the base according to the installation environment so that the product is not submersed in water. The default height of the base is 200 mm and it must be at least doubled in areas with double the snowfall of 100 mm or above.
- Install the drain pipe in the drain hole.  
The drainage must be finished so that particles around the drainage do not clog the pipes.
- LG is not responsible for product failure or damage from incorrectly designed or manufactured base.

**CAUTION**

- For the frame, use strong material such as steel angle so that it does not slip from the wind or snow.
- Never install the product so that the suction inlet and the discharge output of the chiller faces the seasonal wind.
- When making the base platform, pay special attention to the strength of support, drainage and direction of pipe and wiring.

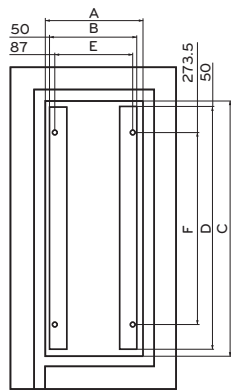

\* Location of anchor bolt

Classification	1 UNIT	2 UNIT	3 UNIT
A	865	1 628	2 391
B	765	1 528	2 291
C	2 254	2 254	2 254
D	2 154	2 154	2 154
E	691	1 456	2 217
F	1 707	1 707	1 707

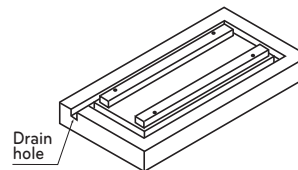
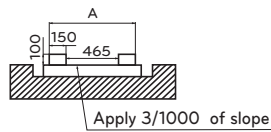

<1 UNIT Drawing of base>

74 INSTALLATION

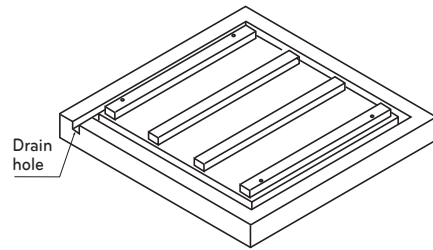
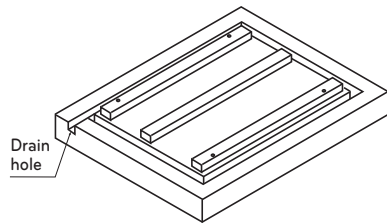
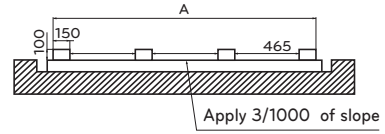
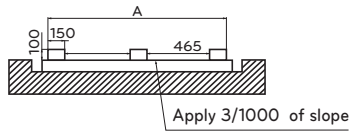
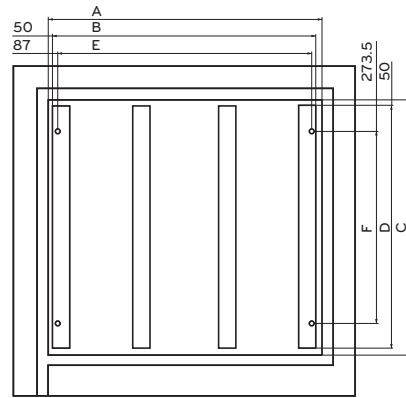
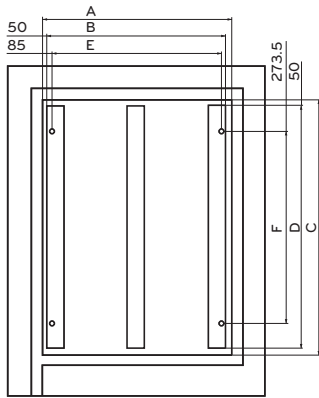

<2 UNIT Drawing of base>

<3 UNIT Drawing of base>

## Transportation method and precaution

### ⚠ CAUTION

#### Be very careful when transporting the product.

- When transporting the product, use the forklift or spreader bar and follow the directions in the manual.
- Do not touch the heat exchanger pin with bare hands. It is very sharp and can cause an injury.
- Cut and dispose the plastic (vinyl) bag used for packaging so that children do not play with the bags. If not, it can cause suffocation when put over the head.
- Always transport the chiller by supporting 4 points. 3 point support is unstable and the product may fall over.
- When transporting the product with the forklift, be careful not to drop the product.
- Use a long belt at least 8 m long.

### Precaution when moving the forklift

- Level the chiller as much as possible while moving it.
- When moving the chiller using the forklift, check the weight and use the forklift with the sufficient capacity to handle the weight.
- When moving the chiller using the forklift, check the transportation groove at the bottom of the chiller and use the fork that fits the grooves.
- The forklift cannot lift the product from front or rear side. Always lift the product up from the side where the grooves are to move the product.

\* The side with the control box is the front side.

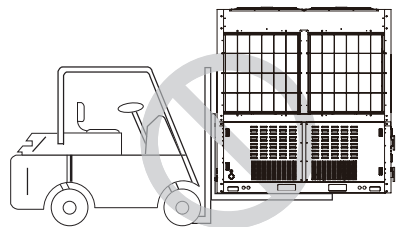
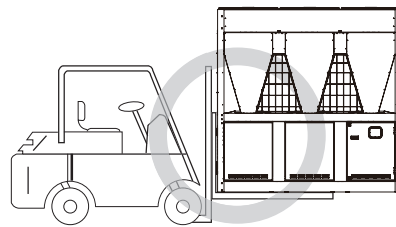

### Precaution when hanging the product

- When moving the chiller, make sure to level the product as much as possible.
- When hanging the chiller, pass the rope through the two supports located at the bottom of the front and rear side.
- Always connect the rope to the 4 supports when lifting up the product so that the impact may not be applied.
- Use the steel spreader bar to use the tension of the ropes to avoid the damage to the product.
- When hanging the chiller, do not tilt the chiller by more than 15 degrees.

\* Spreader bar is the tool to avoid the rope from contacting the product to minimize the damage to the top and the coil.

- Spreader bar is not supplied.
- Spreader bar must be larger than the size of the chiller.
- Even when the spreader bar is close to the top of the product, it must not contact the product.

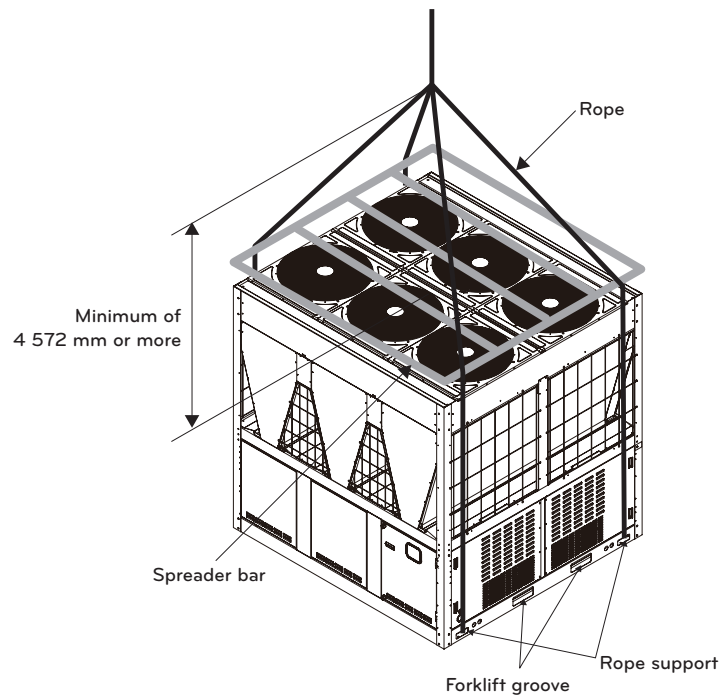

### Storage

If the product must be stored before being installed or used, make sure not to expose the product to dirt and humidity in the construction site. Put a protective cover on the product until it is ready to be installed.

## Installing chiller

As soon as the product is delivered, check for any damages. If there are damages, immediately contact the shipper.

### Precaution when installing the chiller

- Secure air flow, wiring, piping and sufficient space for service.
- Check whether the surface is flat and can withstand the operating weight and vibration/noise of the device.  
(For the part to lift up the product, installation and operating weight, refer to the specification, external diagram and basic diagram.)
- Set the device so that the air flow does not get limited to the suction inlet side only.
- Secure sufficient space to provide service and remove the product.  
(The air flow and service space various based on the model. Refer to the drawing in the Appendix.)
- Check the base before installing the product and install the product only when there is no issue. If there is any issue, contact the contractor to resolve the issue.  
(For checkpoints related to the base, check the details when installing the base.)

### WARNING

- Install the product where the weight of the chiller can be sufficiently supported.  
If the product is installed at a location that cannot support the weight, the chiller can fall down to cause an injury.
- Install the chiller so that it does not fall over even from strong wind and earthquake. IF there is any defect in the installed condition, it can fall over to cause an injury.

### Installing anti-vibration pad

- Anti-vibration pad is the part to absorb the vibration that occurs during the product operation and must be installed before placing the product on the base. Anti-vibration pad is not provided along with the product and must be supplied on site.
- After installing the anti-vibration pad, loosely tighten the anchor bolts. Tightening the anchor bolts too tightly will reduce the anti-vibration effect.

78 INSTALLATION

- Locate the anti-vibration pad shown as below and lay 2 layers of 10 mm or above.

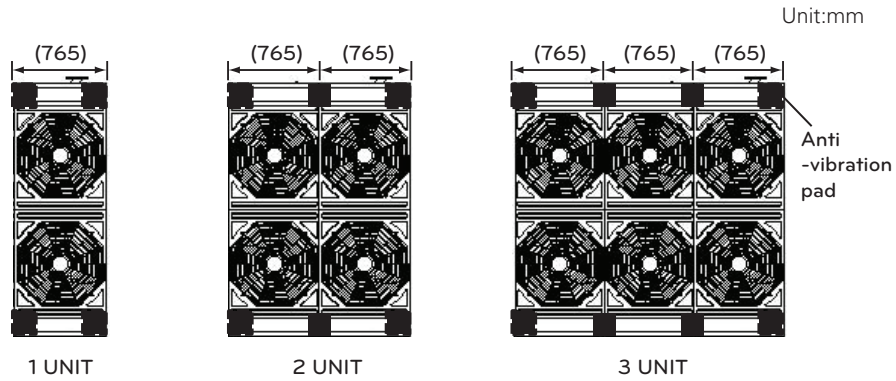

**Installing anchor bolt**



**CAUTION**

- Wooden frame at the bottom of the base frame must be removed before tightening the anchor bolts for the chiller.
- When installing the chiller where it is directly affected by the coastal wind, additional anti-corrosive treatment must be applied to the condenser.
- Tighten the bolts so that the chiller does not fall over from the earthquake or strong wind as shown below.
- Depending on the installed condition, the vibration can be transferred to the installed part to transfer the noise and vibration to the floor or wall. Therefore make sure to use the anti-vibration material.
- Anti-vibration spring can be additionally installed on top of the anti-vibration pad. Check the external diagram and the weight of the product to set the specification for the anti-vibration spring.
- When combining multiple chillers, make sure to level the height of each chiller so that the water pipes can be easily connected.
- Use the anchor bolts to firmly fixate the chiller. The anchor bolt must be inserted at least 65 mm.
- Open left/right panel of the chiller, check anchor bolt fixing hole, and lock the anchor bolt so that it makes right angle with the chiller.

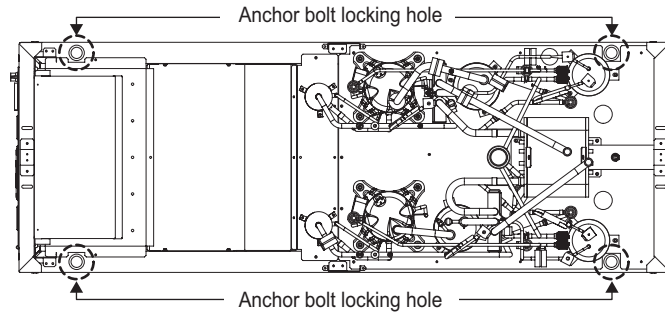

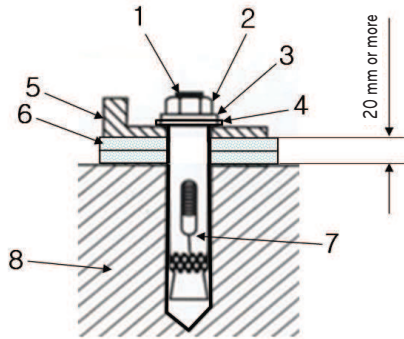

No.	Name
1	Anchor bolt(M16)
2	Nut
3	Spring washer
4	Flat washer
5	Bottom of product
6	Anti-vibration pad
7	Cap
8	Base surface

\* Above parts are not included in the product.

Shape of anchor bolt

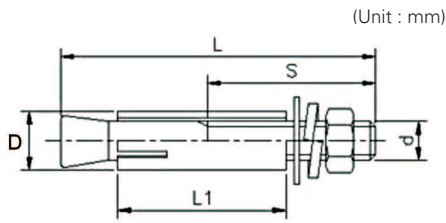

Specification of anchor bolt

Screw size (d)	L	S	D	L1	Used drill	Drill depth (mm)	Pull-out load(N)
5/8" (M16)	125	70	22	65	22	65	42 140

## Snow protection

Areas with heavy snowfall require snow protection plan. For the air cooled scroll cooling only chiller, the snow protection plan ensures sufficient performance.

### Design of snow protection plan

When establishing the snow protection plan, the fan level from the chiller must be at least to some level.

- If the fan level is below a certain level, it triggers the high pressure limit within the circuit to cause an issue in the operation.
- Because the outdoor unit can be frozen inside due to the clogged air inlet from snow, make the arrangement so that the outdoor unit does not directly contact the inlet and install the hood to avoid the effect of the heavy snow.
- Always install the base so that the chiller can be installed higher than the accumulated snow and the default height of the base is 200 mm. If the snowfall is 100 mm or above, raise the base to more than double the height. (300 mm maximum snowfall)
- The height of the base must not exceed the width of the product.
- If there is 100 mm or more snow piled on top of the product, make sure to clean the snow off before operating the chiller.

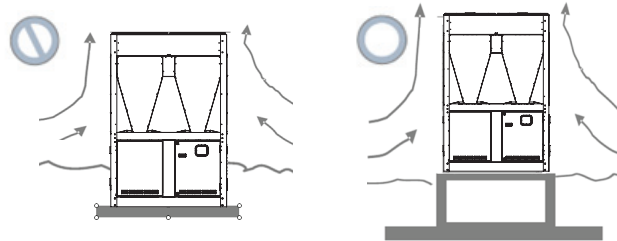

### Installation considering the snow protection

- Do not install the chiller near the edges of the rooftop.  
(Snow can fall down to the chiller and push off the chiller off the roof. If snow is accumulated between the building wall and product, it can cause issues with the product.)
- Raise the base higher than the snow accumulation.  
(Make sure to secure the path near the heat exchanger of the chiller in case of snow)
- Avoid installing the product where the snow is accumulated.





## Water pipe connection

Water pipe construction is a very important part of the design or construction of the cooling system. Any defect in any location of the pipe can disable the applicable unit from performing sufficiently. Perform the design and construction considering the check service.

### Water pipe system diagram

Water circulation that has temperature difference of 3 °C - 8 °C between the outlet water temperature of the hot and cold water is required. If the water circulation is insufficient, the product will not be able to perform properly and will have negative impact on the life of the product, as well as other issues with the product.

Make sure to secure water circulation in accordance with the specification.

Also even when the water circulation is secured in accordance with the specification, bypass circuit must be installed on the 1st side for the water pipe system of the chiller. Therefore if the water flow is reduced during low load, it can cause issues such as excessive and frequent operation of compressor and freezing during stopped condition or cooling operation.

Water circulation must maintain constant flow as much as possible.

\* For the parts used in the cold water pipe system, make sure to use the parts that comply with designed water pressure or higher.

### Expansion tank

Expansion tank is the device that discharges the expanded water and at the same time, removes the air within the water pipe circuit.

Set the capacity of the expansion tank to 2-2.5 times of the water expansion amount. (Generally it is 3-5 % of the entire amount within the water pipe circuit.)

### Pipe slope and air vent

If air remains within the pipe, the resistance of the water pipe circuit increases or the circulating amount of water is reduced significantly. If air remains in the pump during the operation, it can cause several issues to disable the operation.

Install the air vent valve where there is a chance of air remaining within the entire water pipe circuit and apply 1/200 of slope to the air vent valve side to avoid the air from remaining in the pipe.

### Water pipe system diagram

- Connect the pipe so that the entrance of the cold (hot) water pipe is correct.
- Permitted water pressure resistance of cold water pipe system is 1MPa
- To prevent any external heat loss or dew drops forming during the cooling operation on the water pipe system, apply thermal insulation treatment.
- Install the air vent at the output end of the water pipe. (Air vent)
- If the thermometer is installed on the inlet/outlet of the cold/hot water pipe, the operating condition of the chiller can be checked.
- Always install the strainer (50 Mesh or above) that can be cleaned on the water pipe inlet side to filter any alien particles from entering the heat exchanger.
- Always install the strainer on the leveled pipe. (If sand, trash or rust gets mixed to the cold water system, it can cause product failure due to corrosion of metallic parts.)
- Install the on/off valve on the cold water inlet/outlet and bypass pipe on the pipe direction of the device side.

- For the pipe system, it is recommended to install the bypass and clean the pipe before installing the product and during the annual pipe cleaning.
- On/Off valve blocks the old water to the chiller that is not operating to reduce the power of the pump. Therefore select whether to install to fit the need of the site.
- Install the pressure gauge and thermometer on the inlet and outlet of the water pipe.
- Always install the flexible joint to reduce the vibration of the pipe and product.
- Vibration of water pipe system is absorbed to prevent water leakage.
- For the cold water system part, make sure to use the component that complies with designed water pressure or above.
- Before supplying cold water to the chiller, clean inside the pipe system to remove any negative impact of particles to the product.



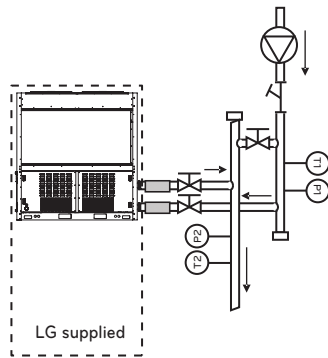

**Installation mode A (Recommended method)**

\* Independent product installation

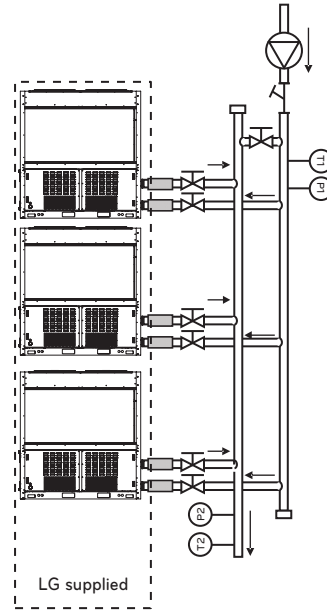

\* Independent product installation



Symbol	Description	Symbol	Description
	Valve	<b>T1</b>	Temperature sensor (1: Inlet 2: Outlet)
	Strainer	<b>P1</b>	Pressure gauge (1: Inlet, 2 Outlet)
	Flexible joint		Cold water pump



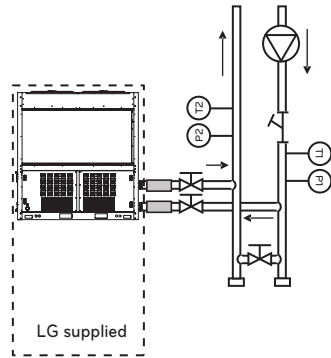

**Installation mode B**

\* Independent product installation

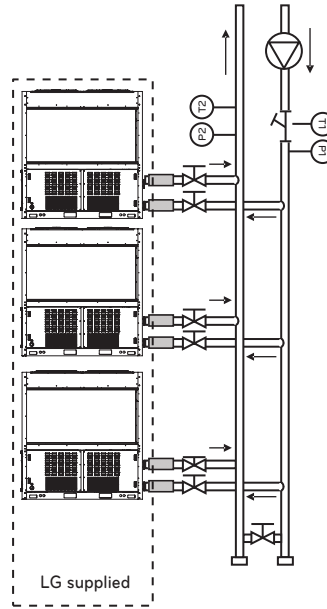

\* Independent product installation



Symbol	Description	Symbol	Description
	Valve	<b>T1</b>	Temperature sensor (1: Inlet 2: Outlet)
	Strainer	<b>P1</b>	Pressure gauge (1: Inlet, 2 Outlet)
	Flexible joint		Cold water pump

**Water pipe connection****CAUTION**

- If the winter outdoor temperature is 0 °C or below, take following measures to prevent the pipe from freezing as shown below.
  - If the outdoor temperature is low, the circulation water can freeze to damage the heat exchanger of the product when the product is stopped.  
If there is possibility of damage from low outdoor temperature, operate the pump to prevent the water from freezing.
  - If the product does not operate for a long period of time during the winter season, remove all the circulation water to prevent the damage of heat exchanger and pipe from freezing.
  - Add anti-freeze additive to prevent the circulation water from freezing during the winter season.
- Maintain the cold water flux within the designed flux to ensure appropriate chiller performance and reduce the tube damage from rusting, scaling and corrosion. LG is not responsible for any damage of chiller from poor water quality management or inappropriate processing water.

**1 Water pipe installation**

- Appropriate pressure of pipe connection is flange connection of 1 MPa or below.
- Size of the water pipe must be the same as that of the product or larger.
- If there is risk of dew drops forming, always install the thermal insulation material on the outlet pipe of the cold water.
- To avoid connected water pipe from creeping from the load, use appropriate hook for support.
- To prevent the pipe connected part from freezing during the winter season, always install the drain valve at the most bottom of the pipe system.
- Cold water inlet pipe is located at the bottom and the outlet pipe is installed on the top.

2 Cold water pump control

- If the cold water pump is not operating for a long period of time or if the anti-freeze liquid is not used as the cold water, the anti-freeze pump control must be installed to prevent the pipe from freezing.
- The vibration of the pump can transfer to the pipe to cause noise indoors. As the plan to prevent the noise from spreading in the pump, install flexible joints at the inlet/outlet and use the anti-vibration amount for the pump support.

3 Cold water management

The water quality of the cold (hot) water is described as follows. The water quality must not fall below the following standard. If so, it can be judged to have risk within relatively short period of time.

Item		Cold water	
		Circulation type cold water	Cold water
Reference	PH(25 °C)	6.5 - 8.0	6.5 - 8.0
	Conduction rate (25 °C μs/cm)	500 or below	200 or below
	Alkali level (PPM)	100 or below	50 or below
	Hardness (PPM)	100 or below	50 or below
	Chlorine ion (PPM)	100 or below	50 or below
	Lactic acid ion (PPM)	100 or below	50 or below
	Iron (PPM)	0.1 or below	0.3 or below
	Sulfur ion (PPM)	Not detected	Not detected
	Ammonium ion (PPM)	0.5 or below	0.2 or below
	Silica (PPM)	50 or below	30 or below

**Precaution to prevent freezing**

If the product does not run when the outdoor temperature is 0 °C or below during the winter, the water must be drained or anti-freeze additive must be added to prevent the water from freezing.

Input pipe must be installed to be leveled.

The pipe must be leveled and installed so that water does not remain in the inlet pipe connected to the product when draining the water through the drain hole.

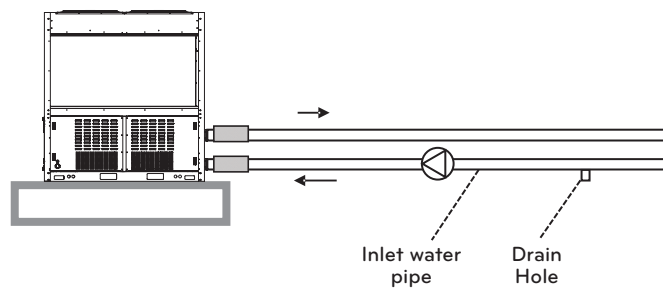

If the inlet water pipe is installed in trap structure without being leveled, the water will remain in the inlet water pipe even when the pipe is drained and the inlet water pipe or the part within the chiller can be damaged from freezing. Therefore add a drain hole at the bottom of the pipe as shown below.

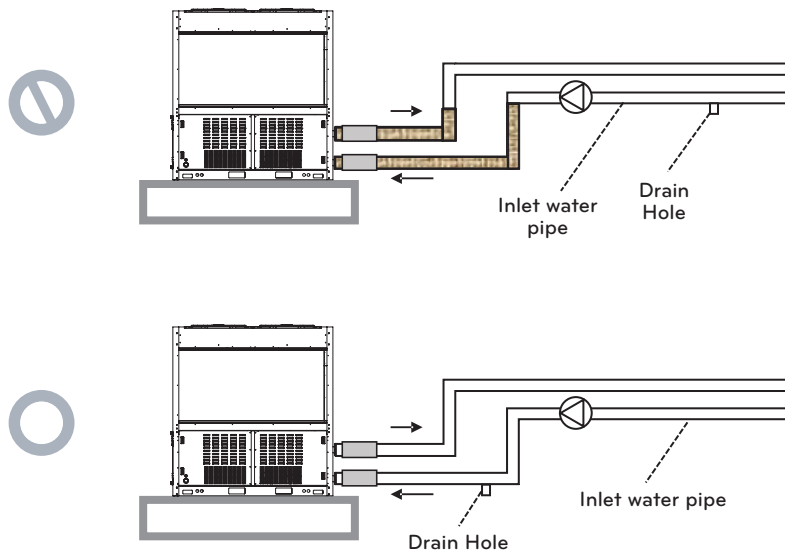

## Electric specification

UNIT	Frequency(Hz)	Voltage(V)	Voltage range
1 UNIT	50	380-415	342~457
2 UNIT	50	380-415	342~457
3 UNIT	50	380-415	342~457

- 1 Voltage range  
The chiller must be operated at the voltage within the upper and lower limit supplied from the power terminal to operate normally.
- 2 Maximum voltage variance permitted between phases is 2 %.



### NOTE

MCA: Minimum Circuit Ampere, A  
MOP: Maximum Overcurrent Protection



### WARNING

- Always use regulated wire so that the connector of the terminal does not fall off from external force. If the connector is not fixed firmly, it can cause heating, resulting in a fire.
- Always use appropriate over-current protection switch. Generated over-current includes low level of DC.
- Leakage current circuit breaker for grounding must be installed. If not installed, it can cause electric shock.
- Use only the circuit breaker and fuse of accurate capacity. Using fuse, wire or copper wire with excessive capacity can cause malfunction or a fire.
- Do not connect the 3 phase 3 wire type connection in reverse/missed phase.

## Electric work

### Precaution

- 1 For regulation related to electric device and wire, follow the regulation of the technical standard and government organization and the guide of the power company.

#### ! WARNING

Electric work using special circuit based on the overall regulation and this manual must be done by qualified electrician.  
If the capacity of the power supply circuit is insufficient or if there is a defect, it can cause electric shock or fire.

- 2 Directions of Power and Communication cable connections differ depending on the product volume.  
1UNIT and 2UNIT use the connection terminals located at the right when viewing from the front. 3UNIT uses the connection terminals located on the left.

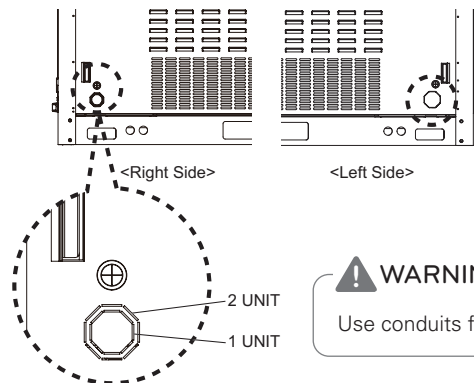

#### ! WARNING

Use conduits for power cable installation.

- 3 Separately install the communication and power cable of the chiller so that the communication cable is not affected by the electric noise generated from the power cable. (Do not pass through the same electric pipe)
- 4 Always ground the wires as indicated.

#### ! WARNING

Always ground the chiller. Do not connect the grounding wire to the gas pipe, water pipe, lightning rod or telephone grounding wire. If the grounding is unstable, it can cause electric shock.

- 5 Use 2-line shield cable as the communication cable. If 1 line shield cable is connected to another system, the communication quality of receiving and sending will be poor causing issues.



**! WARNING**

- When connecting the power cable, always connect after connecting the ring terminal. It can cause fire and burn the electric part.
- The voltage imbalance rate between phases must not be higher than 5 %. If higher than 5 %, the product life may be shortened.
- Use 2 line shield cable
- Do not wire in parallel to the power cable.
- Do not use multiple lines.

6 For the communication terminal, use only the regulated communication cable.

**Electric connection**

**! WARNING**

Electric shock may result in injury or death. The power must be completely turned off while installing the product.  
Because there may be more than 1 switch, attach the warning label to all locations with the switch so that the power is not recovered until the work is fully completed.

- 1 Power  
The electric characteristics of the power must be aligned with plate of the device. Supplied voltage must be within labeled limit.
- 2 Power cable connection and wiring.  
Refer to the wiring diagram to connect the power cable.  
Connect R, S, T, and N of the power cable separately to the circuit breaker in case of 1UNIT or to Main terminal block in case of 2UNIT or 3UNIT.  
  
All power wiring must comply with the regulation of the applicable area and nation. Refer to the wiring diagram and electric specification.  
Do not turn off the power unless the chiller is not used for a long period of time.  
If power is not connected to the oil heater on the bottom of the compressor, the chiller may be damaged or the system may stop.
- 3 Control power  
When using the power, control power is supplied from the main power and separate power supply is not required.
- 4 Additional wiring  
Refer to the wiring diagram for on-site wiring. Only the main panel (HMI installed panel) requires wiring at the site. Control box is already fully wired out of the box.  
\* On-site wiring location
  - Pump output: DO3
  - Modbus: CH4 A, B
  - Pump interlock: UI6, G
  - Remote alarm: DI3, GND
  - HMI power: External board 12V, GND (When installing outdoor, use separate power cable for indoor installation)
  - Remote operation: DI1, GND

90 INSTALLATION

5 Circuit breaker and power cable connection

Maximum of 5 chillers can be connected.

When installing the power cable, jump one power cable and do not connect to other chiller.

Always distinguish chiller for installation.

When installing several chillers, install the circuit breaker by each chiller.

Refer to the general data of the product information when selecting the capacity for the circuit breaker.

Correct installation

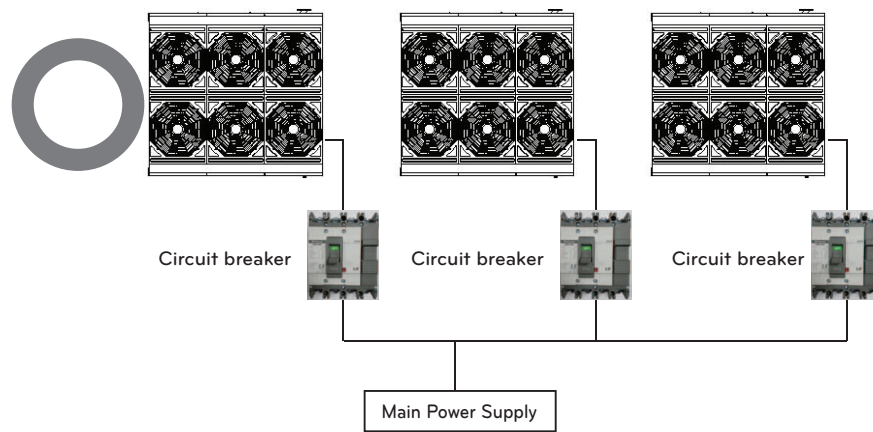

Incorrect installation

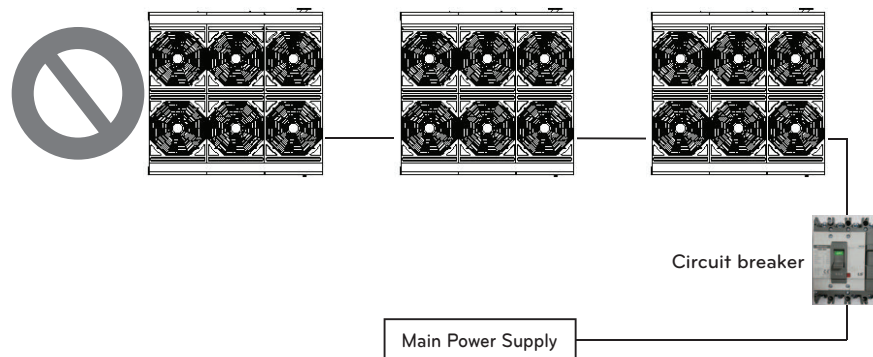

### How to set control box address (Set cycle PCB address)

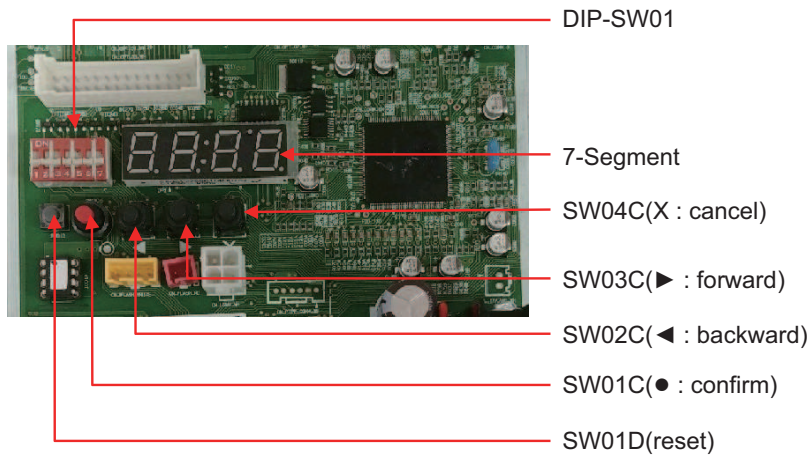

- 1 Select the address by turning the dip switch #5, #6 and #7 on the top right corner of PCB ON/OFF.  
 \* If there is only 1 cycle PCB connected to the main controller of the chiller, use the address #1 only and if there are 2 cycle PCBs, use only #1 and #2 to select the address.

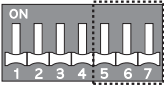
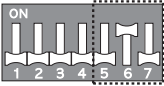
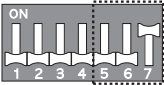
Cycle address: 1 (Dip switch: #6, #7 OFF)	SW01B 
Cycle address: 2 (Dip switch: #6 ON / #7 OFF)	SW01B 
Cycle address: 3 (Dip switch: #7 ON / #6 OFF)	SW01B 

## 92 INSTALLATION

- 2 After selecting the cycle address with the dip switch, always press the Reset button to complete the setting.

 **WARNING**

- If there is only 1 cycle PCB connected to the main controller of the chiller, use the address #1 only and if there are 2 cycle PCBs, use only #1 and #2 to select the address. Or else the product will not operate.
- When replacing the cycle PCB of the control box, always run an automatic address setting again.  
This must be performed with all cycle PCB and HMI PCB connected. If not, it will result in operation error.
- When setting the address, check and change other control box PCB address within the chiller. PCB address for replacement is set to 1. If control box PCB address is duplicated, the product will not operate.  
Control box PCB address is set to 1, 2 and 3 in order as factory default.

## How to install HMI indoors

### ! CAUTION

- HMI is designed to basically be installed and used on the wall.
- This example describes how to install HMI on the wall.
- If the wall is firm, prior work is required to drill the screws.
- Communication cable for indoor installation is not included in the components.
- It is recommended to use communication cable of 0.75 square or above.

Decide the space to install HMI. Before fixing the HMI, check whether it is an appropriate location to connect the communication cable and power cable to HMI.

Use the drier and M4 screw on the top wall of the communication cable to fixate the rear panel of HMI. It can be fixated as shown below depending on the installed location.

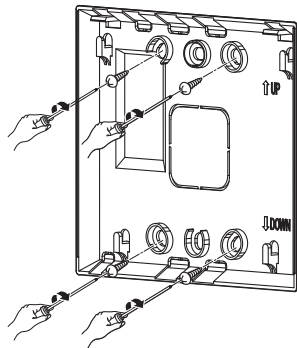

Pull out the communication cable through the hole on the rear side of the panel.

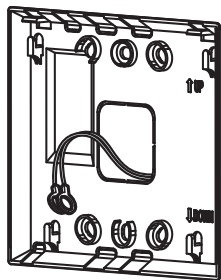

**! CAUTION**

- Because different polarities exist on the communication cable, make sure not to mix them.
- To prevent incorrect wiring, it is recommended to mark A and B on the communication cable.
- Use the ring or Y terminal for connecting to the control box terminal of the communication cable.
- Refer to page 16 "Internal configuration of control panel" for location of control box terminal.

Connect the socket to the communication port located on the rear side of the HMI.

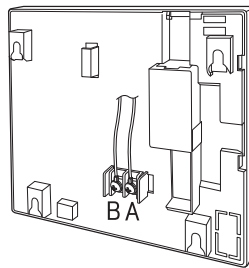

Connect the power adapter (Component) to the power terminal located on the rear side of the HMI.

Assemble the main unit of HMI to the rear panel installed on the wall. After hanging the hole of the top of the main unit to the top of the rear panel, push the bottom of the unit to assemble it.

Connect the power cord of the power adapter to the power plug.

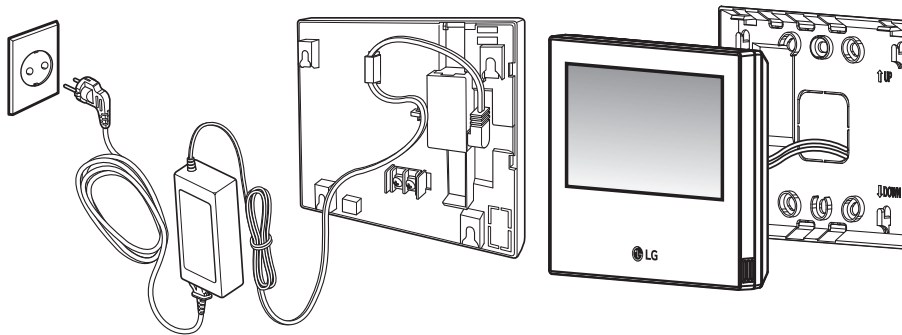
**! CAUTION**

If the power cord of power adapter and power cord must be buried due to short distance, it requires space of 120 mm x 80 mm x 80 mm to arrange the power adapter and power cord.

## TEST RUN/ADDITIONAL FUNCTION

### Test run

#### Checkpoint before test run

Start the chiller after checking the following.

- Before starting the chiller, check the supplementary devices such as cold water circulation pump, AHU or other devices. Refer to the directions from the manufacturer. If all equipped parts are installed on the device, check whether all parts are installed appropriately and accurately and check whether the wiring is done correctly. Refer to the wiring diagram of the product.
- Check the flow switch for appropriate operation of the product. Check whether the sensor is operating properly.
- For cooling, fill up cold water circuit with clean water or other non-corrosive liquid and purge the air so that there is no air remaining inside the cold water circuit. If the outdoor temperature is expected to drop below 0°C, add anti-freeze additive to the cold water circuit to prevent the water from freezing. Cold water circuit must be cleaned before connecting to the product.
- Check and inspect all water pipes. Check whether the direction of the water flowing is correct and whether properly connected to the evaporator. Open all flow valves to the evaporator side.
- Turn on the cold water pump and measure the overall water pressure reduction of evaporator to check whether the flow is accurate compared to the designed flow rate.
- Check all electric connections within the control panel and whether all parts are tightly assembled with good contact conditions. Though the connecting part is checked from the factory but it can be loosened during the transportation from the vibration.
- Check and inspect all fuses. All fuses within the power panel and control panel must be installed at appropriate location.

#### Starting procedure

The chiller can be started as follows.

- Check whether the load is operating on the air processing device or other device on the side of the water that supplies the water to the chiller. If the temperature of the cold water is too high, the start of the load device on the water side can be delayed.
- If auto control does not work from the chiller, check whether the water circulation pump is operating.
- Voltage variance must be within 10 % and check that the phase voltage imbalance does not exceed 5 % between phases. Check whether the power and capacity is appropriate for processing the load.
- Check the order of the power phase.
- Check and inspect the voltage monitoring meter within the power panel. The meter should not show any error code.
- Use the HMI device to check the cold water outlet temperature and cooling water output temperature setting.
- Set the start menu of HMI device to start the system. Water circulation flow must be within the permitted range to control the temperature appropriately.

**Check during start**

After the above procedure, start the chiller to check whether everything works normally. If there is any issue, immediately stop the product and follow the "Troubleshooting" process. Refer to the Appendix for the criteria of each detail. Follow the below procedure for checkpoints when starting the chiller.

- Check the rotating direction of the condenser fan motor. Place newspaper or tissue to check whether the air flow is normal around the motor.
- Check whether the cold water outlet temperature is the same as the setting.
- Through HMI device, check whether all sensors show effective values. Temperature sensor detects the compressor discharge temperature, compressor suction temperature, condenser outlet temperature and cold water inlet/outlet temperature.
- Check whether the operating current, operating noise and vibration is the same as the product specification.

**Stop**

After completing to check based on the above procedure, stop the product. After the above procedure, start the chiller to check whether everything works normally. If there is any issue, immediately stop the product and follow the "Troubleshooting" process. Refer to the Appendix for the criteria of each detail. Follow the below procedure for checkpoints when stopping the chiller.

- Press the stop button from HMI.
- Measure the stopping time of the actual product after pressing the stop button.
- Stop the cold water pump.

**Load operation and operation adjustment**

After starting and stopping the product, check the product function by operating the load and adjusting the operation. Adjust the cold water outlet temperature setting to adjust the load to check the product while changing the operating condition.

**Prepare operation data**

Always record the operating condition when operating the chiller to check whether it is operating normally compared to the specification. Refer to 'the standard operation record' page of Appendix.

**Analyze water quality of cold water**

Analyze the water quality during the test run and secure the data. Compare the water quality analysis result after a certain period of time (monthly check is recommended) against that of test run to decide the period to change the water.



## Additional function

### Dip switch setting

The dip switch setting of the control box for additional function is as shown below. Change the dip switch setting of individual cycle control box PCB to select the functions in the following table.

**Night low noise function**

This function judges the hottest day time during the cooling operation to reduce the fan noise of the outdoor unit at night time with low cooling load by running the outdoor unit fan at low RPM.

\* How to set maximum RPM

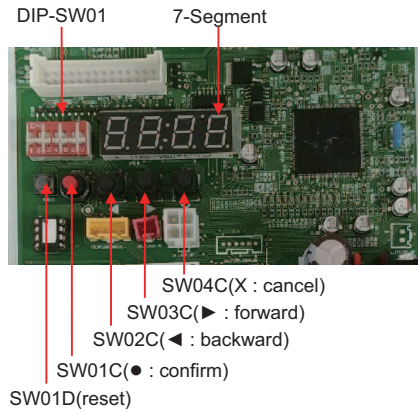
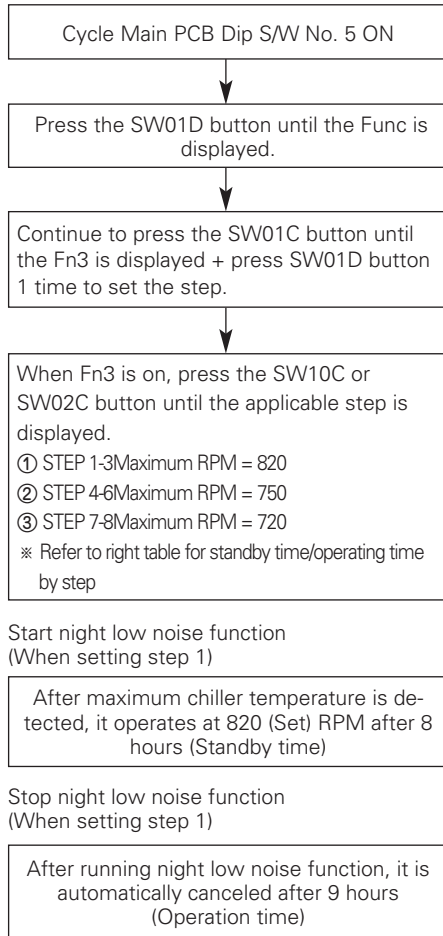

\* RPM/Time setting

Step	Maximum fan RPM	Standby time (Hr)	Operation time (Hr)
1	820	8	9
2		6.5	10.5
3		5	12
4	750	8	9
5		6.5	10.5
6		5	12
7	720	8	9
8		6.5	10.5
9		5	12
10	820	0	Continuous operation
11	750	0	Continuous operation
12	720	0	Continuous operation

**CAUTION**

- Reset the main board of the cycle control box before running this function.
- Request the function setting to the installation expert after installing the chiller.
- If the function is not used, turn the dip switch OFF and reset the power.
- If chiller RPM is changed, the cooling capacity may be reduced.

## SELF DIAGNOSIS FUNCTION

### Self diagnosis function

This function self diagnose the product and displays the error type.  
Error is displayed in the popup window as shown below in HMI and if the error is resolved, press the "Reset" button on HMI to close the error window.



#### - OK button

This is the button to close the alarm popup window.  
Alarm popup window is closed for user convenience from the screen but the current alarm status is maintained.

#### - Error code

Error code is configured as follows.

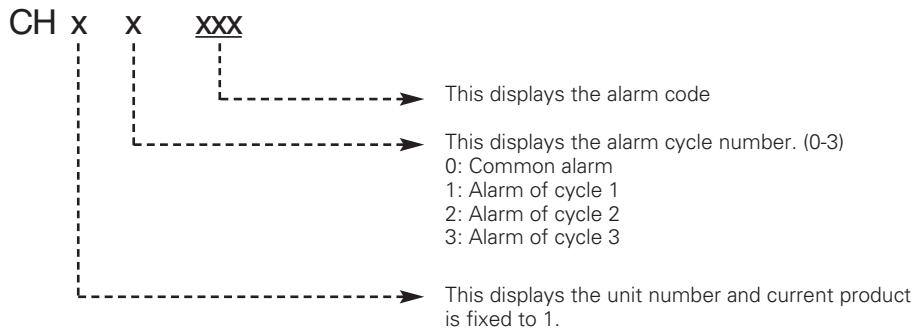

**Process alarm (error)****- Common alarm (error)**

CH10XXX error basically stops the product

**- Alarm (Error) by cycle**

When the alarm occurs by cycle, applicable cycle is maintained at stopped condition and normal cycles operate normally.

If the alarm from the cycle is canceled, it resumes normal operation.

**CAUTION**

When composed of 3 cycles, overall product condition maintains the operating condition even when 2 cycles are in error condition, and the overall product will stop only when all 3 cycles are in error condition.

## HEAT SOURCE WATER MANAGEMENT

### Heat source water management

- Maintain the supplied heat source water temperature in the boundary of 10 °C ~ 45 °C. Otherwise, it may cause product failure.
- The flow speed of the supplied heat source water shall be adjusted adequately. Otherwise, it may cause abnormal noise, pipe vibration, or pipe contraction or expansion by temperature. Use the heat source water pipe with the size of the same diameter of the product connection or bigger.
- Refer to the following table for the heat source water pipe gauge and flow speed. As the flow speed is faster, the noise, corrosion, and inflow of air bubbles increase.

Diameter (mm)	Speed Boundary (m/s)
< 50	0.6 – 1.2
50 - 100	1.2 – 2.1
100 <	2.1 – 2.7

- Caution is required for water quality management. Otherwise, it may cause heat source water pipe corrosion and product failure.
- If the water temperature is 40 °C or higher, corrosion may occur, so it is better to add anti-corrosion solution.
- Install the pipe, valve, gauge, and sensor where the maintenance is easy. Install the heat source water pipe valve at a low position for draining when it is necessary.
- Be careful not to have inflow of air. Air makes the flow speed unstable during the circulation of the heat source water and may degrade pump efficiency and generate heat source water pipe vibration. Therefore, install air purge at appropriate places where air generations are expected.
- Use the following methods to prevent freezing. Otherwise, there is a risk of freezing in the winter.
  - \* When the temperature drops, before the freezing, circulate the water with pump.
  - \* Operate boiler to maintain room temperature.
  - \* If it is not operated for a long period of time in the winter, drain the cooling tower water.
  - \* Use freezing prevention solution.
  - \* Refer to the following table for minimum addition amount of freezing prevention solution for each freezing temperature.

Types of freezing prevention solution	Minimum temperature (°C) to prevent freezing					
	0	-5	-10	-15	-20	-25
Ethylene glycol (%)	0	12	20	30	-	-
Propylene glycol (%)	0	17	25	33	-	-
Methanol (%)	0	6	12	16	24	30

- \* If freezing prevention solution is added, it may cause increased heat source water system pressure drop or product performance degradation.

#### CAUTION

- Sealed type cooling tower is recommended.
  - If open type cooling tower is applied, use middle heat exchanger to make the heat source water supply system to be sealed type.
  - If middle heat exchanger is not used and open type cooling tower is directly connected to the product, product may be severely damaged by foreign object, etc., and in such case, free repair will not be possible.

### Heat source water quality management standard table

Water with a lot of foreign object causes corrosion or scale generation in the condenser and pipe and may affect the performance and lifespan.

Use heat source water suitable for [Environment Policy Basic Act Enforcement Ordinance Environment Standard].

If water other than tap water is used in the cooling tower water supply, make sure to have water quality inspection.

- Heat source water quality management shall follow the standard table below.

If heat source water is not managed according to the water quality standard table, it may cause air conditioner performance degradation or severe product problem.

Category	Sealed type system		Influence	
	Heat source water	Supplementary water	Corrosion	Scale
Basic category				
pH [25 °C]	7.0~8.0	7.0~8.0	0	0
Electrical conductivity [25 °C](mS/m)	30 or less	30 or less	0	0
Chloride ion(mg Cl <sup>-</sup> /l)	50 or less	50 or less	0	-
Sulfate ion(mg SO <sub>4</sub> <sup>2-</sup> /l)	50 or less	50 or less	0	-
Acid consumption [pH 4.8] (mg CaCO <sub>3</sub> /l)	50 or less	50 or less	-	0
Total hardness (mg CaCO <sub>3</sub> /l)	70 or less	70 or less	-	0
Calcium hardness (mg CaCO <sub>3</sub> /l)	50 or less	50 or less	-	0
Ion-silica (mg SiO <sub>2</sub> /l)	30 or less	30 or less	-	0
Reference category				
Iron (mg Fe/l)	1.0 or less	0.3 or less	0	0
Copper (mg Cu/l)	1.0 or less	0.1 or less	0	-
Sulfate ion(mg S <sup>2-</sup> /l)	Shall not be detected	Shall not be detected	0	-
Ammonium ion(mg NH <sub>4</sub> <sup>+</sup> /l)	0.3 or less	0.1 or less	0	-
Remaining chlorine (mg Cl/l)	0.25 or less	0.3 or less	0	-
Free carbon dioxide (mg CO <sub>2</sub> /l)	0.4 or less	4.0 or less	0	-
Stability index	-	-	0	0

#### [Reference]

- (1) 0 mark in the corrosion and scale field means the possibility of generation.
- (2) If the water temp. is 40 °C or higher, the iron without protective coating may have corrosion when it is exposed to water, and addition of anti-corrosion solution or air purge may have a good effect.
- (3) In the sealed type circuit using sealed type cooling tower, coolant and supplementary water shall satisfy the water quality standard of the sealed type system in the table.
- (4) You shall supply tap water, industrial water, or underground water, excluding purified water, neutral water, and soft water, for supplementary water and supplied water.
- (5) The 15 categories in the table are the general causes of corrosion and scale generation

## Water pipe side strainer

For the protection of the water cooling type product, make sure to install strainer of 50 Mesh or more in the heat source water side pipe.

Otherwise, heat exchanger may be damaged by the following conditions.

- 1 The heat source water side in the plate type heat exchanger is formed by several small flow paths.
- 2 If strainer of 50 Mesh or more is not used, foreign object may block some flow paths.
- 3 As a result of the heat exchanger damage by freeze burst, the refrigerant is mixed with the heat source water and the product becomes unusable.

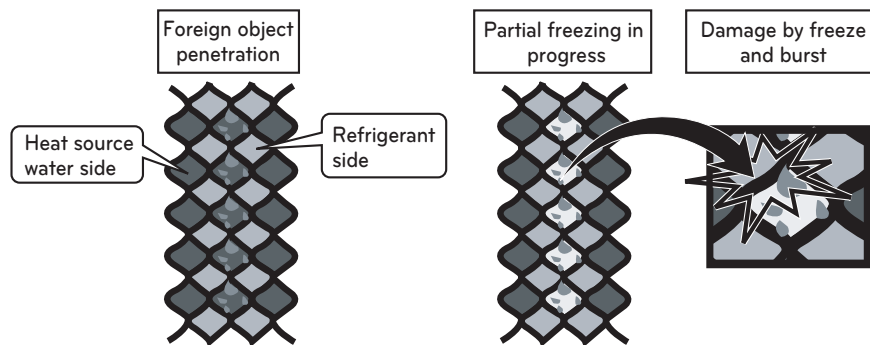

## Actions for problems in the test operation

Category	Status	Cause	Inspection and Action
Whether heat source water is supplied	CH 13	It is the error detected with regards to the heat source water during the flow switch connection, and heat source water does not flow, or flow amount is insufficient. (All operation conditions)	Check if heat source water supply pump works.
			Check blocking of the heat source water pipe. (Strainer cleaning, valve locked, valve problem, air in the pipe, etc.)
			Check flow switch problem. (Flow switch disorder, unauthorized handling, disconnection, etc.)
	CH 180	Heat source water does not flow, or flow amount is insufficient.	Check if heat source water supply pump works
			Check blocking of the heat source water pipe. (Strainer cleaning, valve locked, valve problem, air in the pipe, etc.)

## Plate type heat exchanger maintenance

As scale generation is accumulated, plate type heat exchanger efficiency may be decreased or damage may occur by freeze and burst with decreased flow amount.

For such reasons, it is necessary to have periodical management to prevent scale generation.

- 1 Before entering the usage season, check the following items. (Period: 1 time per year)
  - 1) Perform water quality inspection to see if it is within the standard condition.
  - 2) Perform strainer cleaning.
  - 3) Check if the flow amount is adequate.
  - 4) Check if operation environment is adequate. (Pressure, flow amount, water outlet temperature, etc.)
- 2 To clean the plate type heat exchanger, follow the procedures below. (Period: 1 time per year)
  - 1) Check if service port is mounted on the water pipe for chemical solvent cleaning. 5% diluted formic acid, citric acid, oxalic acid(water acid), acetic acid, phosphoric acid, etc. are suitable as the chemical solvent for scale cleaning. (\* Hydrochloric acid, sulfuric acid, nitric acid, etc. have corrosive property, so they may never be used.)
  - 2) During the cleaning, make sure if water inlet and outlet pipe gate valve and drain pipe valve are properly locked.
  - 3) Connect the pipe for chemical solvent cleaning through water pipe service plug, fill the cleaning solvent of about 50 °C ~ 60 °C in the plate type heat exchanger, and circulate with pump for about 2 ~ 5 hours. The circulation time may be different according to the cleaning solvent temperature or amount of scale. Therefore, closely observe the chemical solvent color changes to decide the circulation time for scale removal.
  - 4) After the solvent circulation work, completely drain the chemical solvent in the plate type heat exchanger, fill 1~2 % concentration sodium hydroxide (NaOH) or hydrocarbon sodium (NaHCO<sub>3</sub>) and circulate for about, 15~20 min. to neutralize the heat exchanger.
  - 5) After the neutralization work is completed, clean inside the plate type heat exchanger with clean water. By measuring the pH concentration of the water, you can verify if the chemical solvent is properly removed.
  - 6) If you use other type of chemical solvent in the market, make sure to check if there is any corrosive property against stainless or copper in advance.
  - 7) Receive consultation from the experts in the relevant industry for details of cleaning chemical solvent.



- 3 After cleaning work is completed, operate the product to see if it works properly once again.

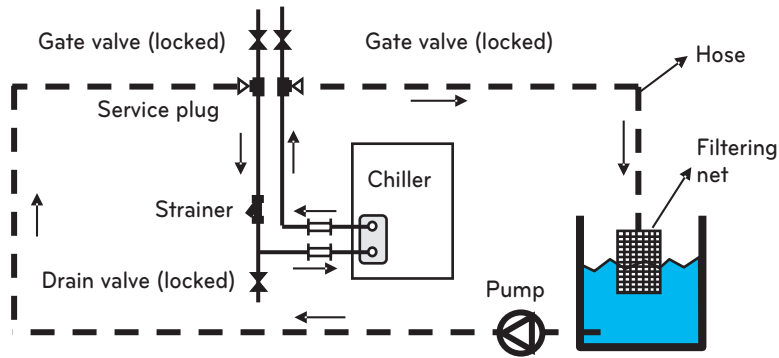

[Plate type heat exchanger cleaning]

## Daily inspection management

### 1 Water quality management

Plate type heat exchanger does not have the structure for disassembly, cleaning, or parts replacement. To prevent corrosion or scale accumulation in the plate type heat exchanger, you have to take a special caution for water quality management. Water quality shall satisfy the minimum suggested water quality category standard. If corrosion prevention solution or corrosion restraining solution is added, you have to use ingredients with no corrosive property against stainless and copper. To prevent the contamination of the circulation water by external air, it is recommended to periodically drain the water inside the water pipe and fill water again even if the circulation water is not contaminated.

### 2 Flow amount management

If the flow amount is insufficient, freeze and burst may occur in the plate type heat exchanger. Check if strainer is blocked or filled with air, and check whether flow amount is insufficient by checking the difference of temperature or pressure between the outdoor unit inlet and outlet water pipe. If there is a difference of temperature or pressure above appropriate level, it shows that the flow amount is decreased, so immediately stop the operation and remove the cause before the re-operation. (\* If there is an air, make sure to perform purge work. The air inside water pipe hinders the heat source water circulation to cause flow amount insufficiency, and it may also cause freeze and burst.)

### 3 Brine concentration management

If Brine(antifreeze) is used in the heat source water, use the designated type and concentration. Calcium chloride Brine causes corrosion of the plate type heat exchanger, so it may not be used. If the antifreeze is left alone, it absorbs moisture from the air and the concentration will decrease and may lead to freeze and burst of the plate type heat exchanger, so minimize the contact area with air and periodically measure the concentration of Brine, and maintain the concentration of Brine by adding Brine as necessary.

Inspection category \ Period (year)	1	2	3	4	5	6	7	8	9	10	11	12	13	14	15
Product operation status	●	●	●	●	●	●	●	●	●	●	●	●	●	●	●
Heat exchanger cleaning	●	●	●	●	●	●	●	●	●	●	●	●	●	●	●
Strainer cleaning	●	●	●	●	●	●	●	●	●	●	●	●	●	●	●
Water quality inspection	●	●	●	●	●	●	●	●	●	●	●	●	●	●	●
Refrigerant leakage inspection	●														●

**CAUTION**

- The above inspection table sets the minimum period, and more frequent inspections are necessary according to installation environment, operation condition / water quality condition.
- During the heat exchanger cleaning, you have to take off the parts such as pressure gauge or lock the valve so that chemical solvent may not enter.
- During the cleaning, check the pipe connection parts in advance to prevent leakage of the chemical solvent.
- Start the cleaning work after the chemical solvent and water are sufficiently mixed.
- It is better to perform the heat exchanger cleaning work in the early stage, and when the scale accumulation becomes severe, it becomes difficult to remove them.
- In the region with poor water quality, periodical cleaning works are necessary.
- Chemical solvent has strong acidic property, so it shall be completely washed with water.
- To verify if the inside became clean, remove the hose and check inside the pipe.
- Make sure to perform the air purge to remove air inside water pipe.
- After the inspection, make sure to check if the heat source water properly flows before restarting the product.

## TROUBLESHOOTING

### General error



#### CAUTION

If the product stopped from the safety device, identify and resolve the root cause before restarting.

Before introducing the special warning, this introduces the general issues and how to troubleshoot the issues.

When the chiller is not operating, check the power, refrigerant, configuration and alarm setting of the chiller.

Check the voltage connected to the terminal block inside the power panel to check the power.

If there is no power, check whether the power circuit breaker is down.

If the power is properly connected, check the cycle pressure of the chiller to check whether it is within the normal range.

If the pressure exceeds the normal range, check for leakage by using the soap bubble.

Before starting the chiller, return to the default setting.

Lastly check the alarm setting. Alarm can be checked through the HMI device.

If the alarm is turned on, follow the troubleshooting method for specific alarm.

Symptom	Potential cause	Potential solution
Device does not start.	Check power of the device	Check over-current protection device Check if fuse is disconnected Resume power to device
	Incorrect or inaccurate device configuration	Check device configuration Check if wiring is incorrect
	Alarm is on	Check alarm condition Check for separate alarm troubleshooting process and resolve the issue Follow the direction Check the HMI input channel to check the alarm condition input
	Entering delay time	Check whether compressor entered start delay time

Symptom	Potential cause	Potential solution
Evaporation pressure is low and the product constantly stops.	Insufficient refrigerant	Check for leakage and refill refrigerant
	Insufficient cold water	Check cold water system (Ensure rated flow) - Is the valve of cold water system closed? - Is the pressure difference between inlet and outlet of cold water system appropriate? - Is the air of cold water system cold?
Condensation pressure is high and the product constantly stops.	Outdoor temperature is high	Check whether outdoor temperature is within operating range
	Alien particles accumulated on the condenser	Clean condenser
	Fan defect	Replace fan
Product vibrates loudly.	Fan-motor connecting bolt is loose	Check assembly condition and tighten bolt
	Motor-mount motor assembly is loose	Check assembly condition and tighten bolt
	Fan is not balanced	After checking fan rotation range, replace fan
	Compressor assembly bolt is loose	If the assembly bolt/nut is loose, tighten it.
	Frame assembly bolt is loose	Check assembly condition and tighten bolt
	Motor bearing is burnt	Check for abnormal noise in motor (Noise in multiple of RPM) and replace motor
Resonance sound	Rubber fixed condition of motor mount is defective	Replace motor mount
	Pipe vibration defect around compressor	Replace anti-vibration rubber attached on pipe
High frequency wave noise from front side of product	Defect in heat emitting fan in control box	Clean part around heat emitting fan
Constantly hunting for cold water temperature	Insufficient cold water	Check cold water system (Ensure rated flow) - Is the valve of cold water system closed? - Is the pressure difference between inlet and outlet of cold water system appropriate? - Is the air of cold water system cold? - Is the cooling load within appropriate range?
Evaporation pressure is high	Temporary rise in cold water temperature due to abnormal increase in load	It is not abnormal. But, check if it is within operating range.

**Alarm**

The description of the alarm is as follows.

Error code	Error name	
	Error condition	
	Control during error	Cancel condition
CHxx001	Outdoor temperature sensor error	
	Outdoor temperature sensor is open/short	
	Stop product	Automatically return to normal condition
CHxx003	HMI communication error	
	When communication between HMI and chiller controller is disconnected for more than 30 seconds	
	Stop product	Automatically return to normal condition
CHxx005	Cycle control box communication error	
	When communication between chiller controller and cycle control box is disconnected for more than 30 seconds	
	Stop product	Automatically return to normal condition
CHxx009	Remote communication error	
	When the modbus communication with the external device is not established for more than 30 seconds after the initial communication with the remote modbus condition is established	
	Stop product	Automatically return to normal condition
CHxx011	Load water pump interlock error	
	When the load water pump is turned off for 3 seconds when starting or during the operation for more than 3 times within 1 hour When turned off more than 9 seconds within 1 hour	
	Stop product	Press the HMI Reset button
CHxx013	Load water flow switch error	
	When the load water flow switch is turned off for 3 seconds when starting or during the operation for more than 3 times within 1 hour When turned off more than 9 seconds within 1 hour	
	Stop product	Press the HMI Reset button
CHxx015	Remote alarm	
	When the contact point signal of hardware wiring is short when entering the remote control mode	
	Stop product	Automatically return to normal condition

Error code	Error name	
	Error condition	
	Control during error	Cancel condition
CHxx021	Inverter compressor IPM fault	
	Inverter compressor drive IPM defect/Inverter compressor defect	
	Stop applicable cycle	Automatically return to normal condition
CHxx022	Inverter compressor input over-current	
	Inverter compressor input over-current	
	Stop applicable cycle	Automatically return to normal condition
CHxx023	Inverter compressor DC link low pressure	
	DC voltage charge defect	
	Stop applicable cycle	Automatically return to normal condition
CHxx024	Cycle high pressure switch operation	
	High pressure switch operates due to abnormal high pressure	
	Stop applicable cycle	Automatically return to normal condition
CHxx025	High/Low voltage of input voltage	
	Over/Under permitted voltage of input voltage, N	
	Stop applicable cycle	Automatically return to normal condition
CHxx026	Inverter compressor start failure error	
	Initial start failure from compressor defect	
	Stop applicable cycle	Automatically return to normal condition
CHxx028	Inverter DC link high voltage error	
	Defect from DC voltage and over-charge	
	Stop applicable cycle	Automatically return to normal condition
CHxx029	Inverter compressor over-current	
	Exceed limit	
	Stop applicable cycle	Automatically return to normal condition

Error code	Error name	
	Error condition	
	Control during error	Cancel condition
CHxx032	Surge in inverter #1,#2 compressor discharge temperature	
	Stop applicable cycle	Automatically return to normal condition
CHxx034	Surge in high pressure	
	Surge in high pressure side	
	Stop applicable cycle	Automatically return to normal condition
CHxx035	Surge in low pressure	
	Drop in low pressure side	
	Stop applicable cycle	Automatically return to normal condition
CHxx036	Low compression rate error	
	Low compression rate error	
	Stop applicable cycle	Automatically return to normal condition
CHxx040	Inverter compressor CT sensor error	
	Inverter compressor CT sensor is short/open	
	Stop applicable cycle	Automatically return to normal condition
CHxx041	Inverter compressor discharge temperature sensor error	
	Inverter compressor discharge temperature sensor is short/open	
	Stop applicable cycle	Automatically return to normal condition

Error code	Error name	
	Error condition	
	Control during error	Cancel condition
CHxx042	Low pressure sensor error	
	Low pressure sensor is short/open	
	Stop applicable cycle	Automatically return to normal condition
CHxx043	High pressure sensor error	
	High pressure sensor is short/open	
	Stop applicable cycle	Automatically return to normal condition
CHxx045	Heat exchanger temperature sensor error	
	Heat exchanger temperature sensor is short/open	
	Stop applicable cycle	Automatically return to normal condition
CHxx046	Suction temperature sensor error	
	Suction temperature sensor is short/open	
	Stop applicable cycle	Automatically return to normal condition
CHxx050	Chiller 3 phase power missing phase	
	Chiller 3 phase power missing phase	
	Stop applicable cycle	Automatically return to normal condition



Error code	Error name	
	Error condition	
	Control during error	Cancel condition
CHxx052	Communication error with inverter controller	
	Communication error with inverter controller	
	Stop applicable cycle	Automatically return to normal condition
CHxx053	Communication failure between Indoor and Outdoor Unit	
	Communication failure between Indoor and Outdoor Unit	
	Stop applicable cycle	Automatically return to normal condition
CHxx054	Reversed phase on Outdoor Unit's 3 phased power source (Reversed connection on RST)	
	Reversed phase on Outdoor Unit's 3 phased power source (Reversed connection on RST)	
	Stop applicable cycle	Automatically return to normal condition
CHxx057	Communication error with inverter controller	
	Communication error with inverter controller	
	Stop applicable cycle	Automatically return to normal condition
CHxx059	Installation Failure of Series Model Outdoor Unit	
	Installation Failure of Series Model Outdoor Unit	
	Stop applicable cycle	Automatically return to normal condition
CHxx060	Inverter PCB EEPROM error	
	Inverter PCB EEPROM error	
	Stop applicable cycle	Automatically return to normal condition
CHxx062	Surge in inverter board IPM temperature	
	Surge in inverter board IPM temperature	
	Correspond cycle stop	Automatic return to a normal condition
CHxx065	Inverter IPM temperature sensor error	
	Inverter IPM temperature sensor is short/open	
	Stop applicable cycle	Automatically return to normal condition
CHxx067	Fan lock	
	Fan locked	
	Stop applicable cycle	Automatically return to normal condition

Error code	Error name	
	Error condition	
	Control during error	Cancel condition
CHxx075	Fan CT sensor error	
	Fan CT sensor is short/open	
	Stop applicable cycle	Automatically return to normal condition
CHxx077	Fan over-voltage error	
	Fan over-voltage	
	Stop applicable cycle	Automatically return to normal condition
CHxx079	Fan start failure error	
	Fan start failure	
	Stop applicable cycle	Automatically return to normal condition
CHxx086	Main PCB EEPROM error	
	Main PCB EEPROM access error	
	Stop applicable cycle	Automatically return to normal condition
CHxx087	Fan PCB EEPROM error	
	Fan PCB EEPROM access error	
	Stop applicable cycle	Automatically return to normal condition

Error code	Error name	
	Error condition	
	Control during error	Cancel condition
CHxx090	Individual Inletwater temperature sensor error	
	Individual Inletwater temperature sensor is short/open	
	Stop applicable cycle	Automatically return to normal condition
CHxx091	Individual Outletwater temperature sensor error	
	Individual Outletwater temperature sensor is short/open	
	Stop applicable cycle	Automatically return to normal condition
CHxx104	Communication Error between Outdoor Unit	
	Communication Error between Outdoor Unit	
	Stop applicable cycle	Automatically return to normal condition
CHxx105	Fan board communication error	
	Fan board communication error	
	Stop applicable cycle	Automatically return to normal condition
CHxx106	Fan PCB IPM fault	
	Fan PCB IPM fault	
	Stop applicable cycle	Automatically return to normal condition
CHxx107	Fan DC link low voltage error	
	Fan DC link low voltage	
	Stop applicable cycle	Automatically return to normal condition
CHxx113	Liquid pipe temperature sensor error	
	Liquid temperature sensor is short/open	
	Stop applicable cycle	Automatically return to normal condition
CHxx114	Sub cooling Suction temperature sensor error	
	Sub cooling Suction temperature sensor Short/Open	
	Stop applicable cycle	Automatically return to normal condition
CHxx115	Sub cooling outlet pipe temperature sensor error	
	Sub cooling outlet pipe temperature sensor Short/Open	
	Correspond cycle stop	Automatic return to a normal condition

Error code	Error name	
	Error condition	
	Control during error	Cancel condition
CHxx145	Main Board - External Board communication Error	
	Main Board - External Board communication Error	
	Stop applicable cycle	Automatically return to normal condition
CHxx150	Liquid Compression Prevention Error	
	Liquid Compression Prevention Error	
	Stop applicable cycle	Automatically return to normal condition
CHxx151	Reversing valve switching failed	
	Mode switching failed	
	Stop applicable cycle	Automatically return to normal condition
CHxx180	Plate type heat exchanger frozen	
	When the load outlet water temperature is maintained at 3 °C or below after the compressor started or if the low pressure is maintained at less than 660 kPA after the compressor started	
	Stop applicable cycle	Automatically return to normal condition
CHxx193	Surge in fan board heat emitting plate temperature	
	Surge in fan board heat sink temperature	
	Stop applicable cycle	Automatically return to normal condition
CHxx194	Fan board heat emitting plate temperature sensor error	
	Fan board heat emitting plate temperature sensor is short/open	
	Stop applicable cycle	Automatically return to normal condition

# APPENDIX

## External diagram

- Model : 1 UNIT

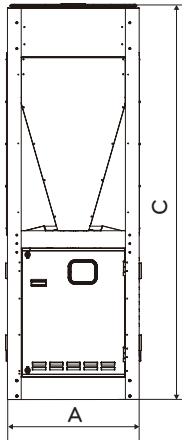

Front view

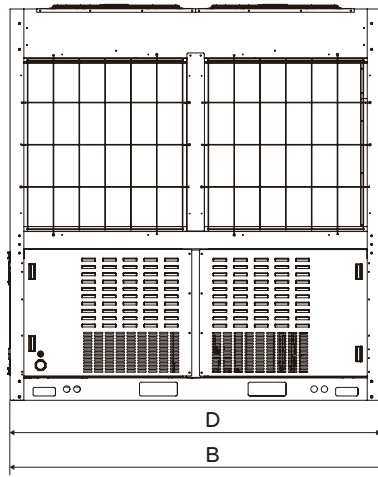

Side view

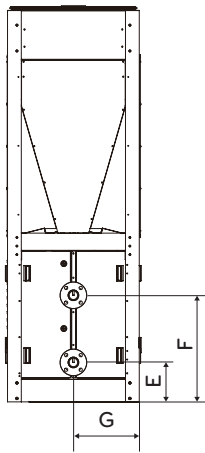

Rear view

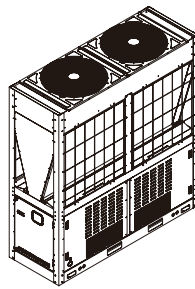

(Unit : mm)

Classification	Dimension
A	765
B	2 198
C	2 300
D	2 154
E	230
F	619
G	382.3

- Model : 2 UNIT

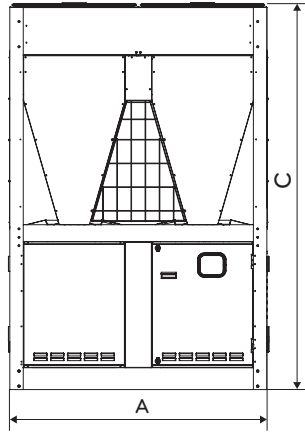

Front view

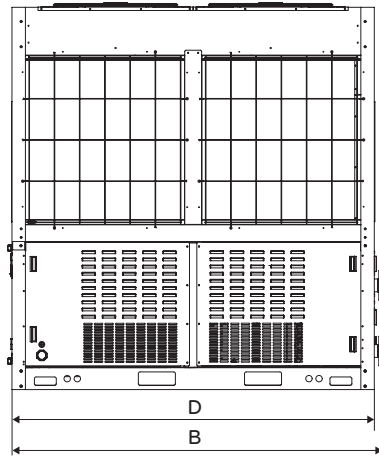

Side view

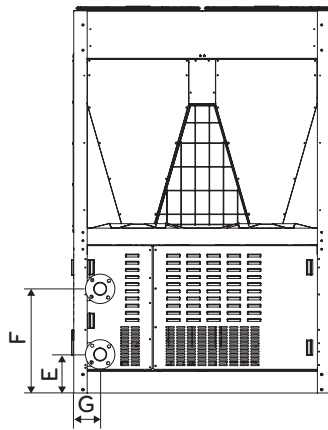

Rear view

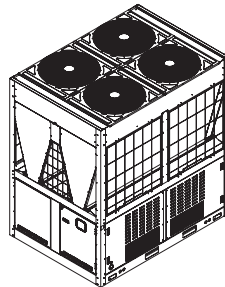

(Unit : mm)

Classification	Dimension
A	1 528
B	2 199
C	2 300
D	2 154
E	230
F	619
G	158.8

- Model : 3 UNIT

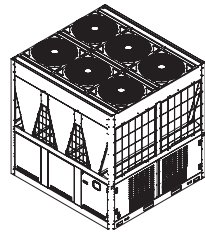
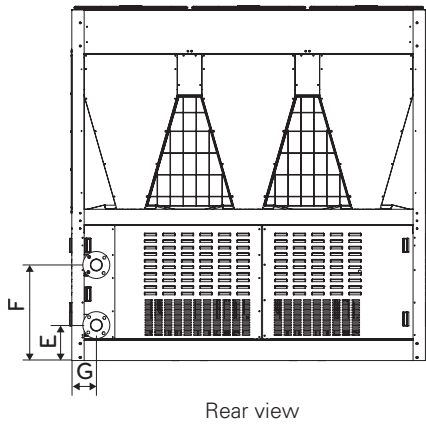
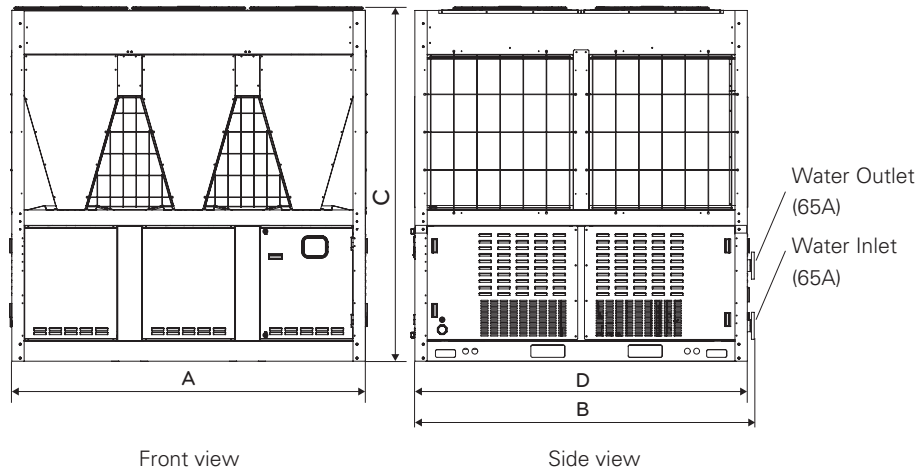

(Unit : mm)

Classification	Dimension
A	2 291
B	2 199
C	2 300
D	2 154
E	230
F	619
G	158.8

Electric Wiring Diagram

- 1 UNIT, 2 UNIT (Main), 3 UNIT (Main)

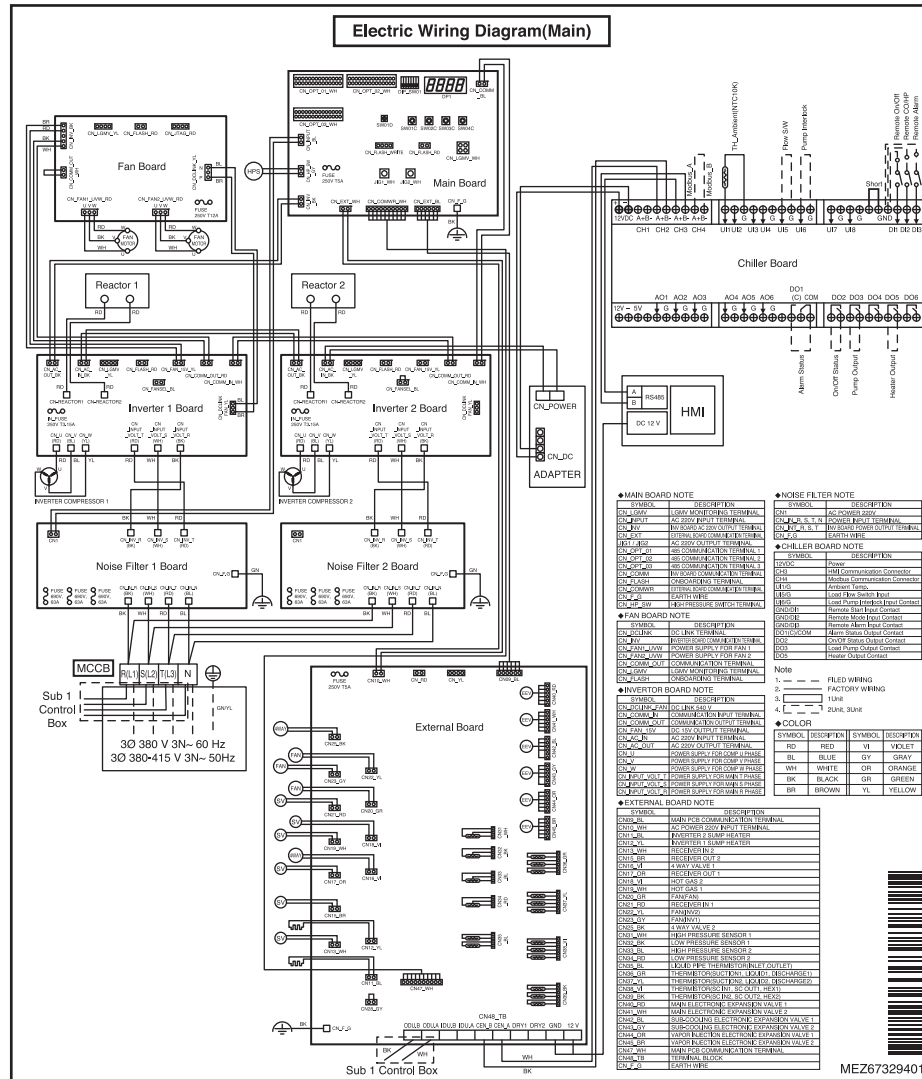







**Cold water head loss curve**

ACHH, Heat Exchanger Pressure Drop Graph

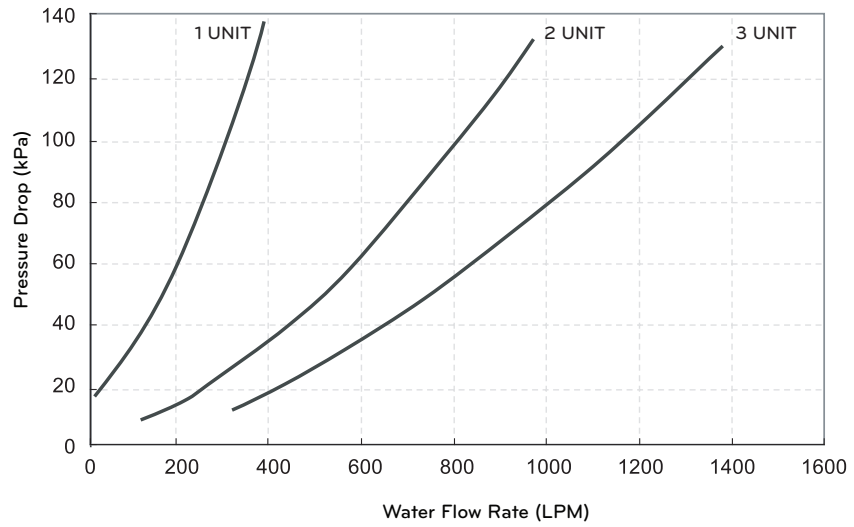

\* LPM : Liter Per Minute

**Modbus protocol**

Coil Register

Register Address	Meaning
1	0:Product Stop 1: Operation Start
2	Reserved
3	0: Keep the Current 1: Delete the Accumulated Operation Time
4~102	Reserved

## Discrete Register

Register Address	Meaning
10001	Reserve
10002	0 : Load Water Flow Switch Off
	1 : Load Water Flow Switch On
10003	Reserve
10004	0 : Load Water Pump Output Off
	1 : Load Water Pump Output On
10005	Reserve
10006	0 : Load Water Pump Interlock Off
	1 : Load Water Pump Interlock On
10007~10104	Reserve
10105	0 : Cycle 1's 4 Way Valve 1 Off
	1 : Cycle 1's 4 Way Valve 1 On
10106	0 : Cycle 1's 4 Way Valve 2 Off
	1 : Cycle 1's 4 Way Valve 2 On
10107	0 : Cycle 1's Hot gas1 Off
	1 : Cycle 1's Hot gas1 On
10108	0 : Cycle 1's Hot gas2 Off
	1 : Cycle 1's Hot gas2 On
10109	0 : Cycle 1's Sump Heater 1 Off
	1 : Cycle 1's Sump Heater 1 On
10110	0 : Cycle 1's Sump Heater 2 Off
	1 : Cycle 1's Sump Heater 2 On
10111~10118	Reserve
10119	0 : Cycle 1's Inverter Compressor 1 Off
	1 : Cycle 1's Inverter Compressor 1 On
10120	0 : Cycle 1's Inverter Compressor 2 Off
	1 : Cycle 1's Inverter Compressor 2 On
10121~10208	Reserve

Register Address	Meaning
10209	0 : Cycle 2's 4 Way Valve 1 Off
	1 : Cycle 2's 4 Way Valve 1 On
10210	0 : Cycle 2's 4 Way Valve 2 Off
	1 : Cycle 2's 4 Way Valve 2 On
10211	0 : Cycle 2's Hot gas1 Off
	1 : Cycle 2's Hot gas1 On
10212	0 : Cycle 2's Hot gas2 Off
	1 : Cycle 2's Hot gas2 On
10213	0 : Cycle 2's Sump Heater 1 Off
	1 : Cycle 2's Sump Heater 1 On
10214	0 : Cycle 2's Sump Heater 2 Off
	1 : Cycle 2's Sump Heater 2 On
10215~10222	Reserve
10223	0 : Cycle 2's Inverter Compressor 1 Off
	1 : Cycle 2's Inverter Compressor 1 On
10224	0 : Cycle 2's Inverter Compressor 2 Off
	1 : Cycle 2's Inverter Compressor 2 On
10225~10312	Reserve

Register Address	Meaning
10313	0 : Cycle 3's 4 Way Valve 1 Off
	1 : Cycle 3's 4 Way Valve 1 On
10314	0 : Cycle 3's 4 Way Valve 2 Off
	1 : Cycle 3's 4 Way Valve 2 On
10315	0 : Cycle 3's Hot gas1 Off
	1 : Cycle 3's Hot gas1 On
10316	0 : Cycle 3's Hot gas2 Off
	1 : Cycle 3's Hot gas2 On
10317	0 : Cycle 3's Sump Heater 1 Off
	1 : Cycle 3's Sump Heater 1 On
10318	0 : Cycle 3's Sump Heater 2 Off
	1 : Cycle 3's Sump Heater 2 On
10319~10326	Reserve
10327	0 : Cycle 3's Inverter Compressor 1 Off
	1 : Cycle 3's Inverter Compressor 1 On
10328	0 : Cycle 3's Inverter Compressor 2 Off
	1 : Cycle 3's Inverter Compressor 2 On
10329~10416	Reserve

## Input Register

Register Address	Meaning
30001	Chiller Controller Version
30002	Entire Operation Current
30003	External Air Temperature
30004	Common Load Water Output Temperature (Average Value of Individual Load Water Outputs)
30005	Common Load Water Input Temperature (Average Value of Individual Load Water Inputs)
30006~30007	Reserve
30008	Information of Refrigerator Failure (1~5)
30009	Cycle Failure Information (0 : Common System Error, 1~10 : Error of Corresponding Cycle)
30010	Failure Code
30011	Start Waiting Time
30012	Stop Waiting Time
30013	Product's Accumulated Operation Time Upper Level
30014	Product's Accumulated Operation Time Lower Level
30015~30100	Reserve
30101, 30102	Cycle 1's Load Water Output Temperature
30103, 30104	Cycle 1's Load Water Input Temperature
30105~30108	Reserve
30109	Cycle 1's Condensation Temperature (Left)
30110	Cycle 1's Condensation Temperature (Right)
30111	Cycle 1's Evaporation Temperature (Left)
30112	Cycle 1's Evaporation Temperature (Right)
30113	Inverter Compressor 1's Frequency of Cycle 1
30114	Inverter Compressor 2's Frequency of Cycle 1
30115	Cycle 1's High Pressure (Left)
30116	Cycle 1's High Pressure (Right)
30117	Cycle 1's Low Pressure (Left)
30118	Cycle 1's Low Pressure (Right)
30119	Cycle 1's Operation Current (Left)
30120	Cycle 1's Operation Current (Right)
30121	Main EEV's Status Value of Cycle 1 (Left)
30122	Main EEV's Status Value of Cycle 1 (Right)
30123~30124	Reserve
30125	Discharge Temperature of Cycle 1's Inverter Compressor1
30126	Discharge Temperature of Cycle 1's Inverter Compressor2
30127	Intake Temperature of Cycle 1's Inverter Compressor1
30128	Intake Temperature of Cycle 1's Inverter Compressor2

Register Address	Meaning
30129	Cycle 1's Liquid Pipe Temperature (Left)
30130	Cycle 1's Liquid Pipe Temperature (Right)
30131	Cycle 1's Hex Temperature (Left)
30132	Cycle 1's Hex Temperature (Right)
30133~30144	Reserve
30145	Accumulated Operation Time of Cycle 1's Inverter Compressor 1 (Upper Level)
30146	Accumulated Operation Time of Cycle 1's Inverter Compressor 1 (Lower Level)
30147	Accumulated Operation Time of Cycle 1's Inverter Compressor 2 (Upper Level)
30148	Accumulated Operation Time of Cycle 1's Inverter Compressor 2 (Lower Level)
30149~30200	Reserve
30201, 30202	Cycle 2's Load Water Output Temperature
30203, 30204	Cycle 2's Load Water Input Temperature
30205~30208	Reserve
30209	Cycle 2's Condensation Temperature (Left)
30210	Cycle 2's Condensation Temperature (Right)
30211	Cycle 2's Evaporation Temperature (Left)
30212	Cycle 2's Evaporation Temperature (Right)
30213	Inverter Compressor 1's Frequency of Cycle 2
30214	Inverter Compressor 2's Frequency of Cycle 2
30215	Cycle 2's High Pressure (Left)
30216	Cycle 2's High Pressure (Right)
30217	Cycle 2's Low Pressure (Left)
30218	Cycle 2's Low Pressure (Right)
30219	Cycle 2's Operation Current (Left)
30220	Cycle 2's Operation Current (Right)
30221	Main EEV's Status Value of Cycle 2 (Left)
30222	Main EEV's Status Value of Cycle 2 (Right)
30223~30224	Reserve
30225	Discharge Temperature of Cycle 2's Inverter Compressor1
30226	Discharge Temperature of Cycle 2's Inverter Compressor2
30227	Intake Temperature of Cycle 2's Inverter Compressor1
30228	Intake Temperature of Cycle 2's Inverter Compressor2
30229	Cycle 2's Liquid Pipe Temperature (Left)
30230	Cycle 2's Liquid Pipe Temperature (Right)
30231	Cycle 2's Hex Temperature (Left)
30232	Cycle 2's Hex Temperature (Right)
30233~30244	Reserve
30245	Accumulated Operation Time of Cycle 2's Inverter Compressor 1 (Upper Level)
30246	Accumulated Operation Time of Cycle 2's Inverter Compressor 1 (Lower Level)
30247	Accumulated Operation Time of Cycle 2's Inverter Compressor 2 (Upper Level)
30248	Accumulated Operation Time of Cycle 2's Inverter Compressor 2 (Lower Level)
30249~30300	Reserve



Register Address	Meaning
30301, 30302	Cycle 3's Load Water Output Temperature
30303, 30304	Cycle 3's Load Water Input Temperature
30305~30308	Reserve
30309	Cycle 3's Condensation Temperature (Left)
30310	Cycle 3's Condensation Temperature (Right)
30311	Cycle 3's Evaporation Temperature (Left)
30312	Cycle 3's Evaporation Temperature (Right)
30313	Inverter Compressor 1's Frequency of Cycle 3
30314	Inverter Compressor 2's Frequency of Cycle 3
30315	Cycle 3's High Pressure (Left)
30316	Cycle 3's High Pressure (Right)
30317	Cycle 3's Low Pressure (Left)
30318	Cycle 3's Low Pressure (Right)
30319	Cycle 3's Operation Current (Left)
30320	Cycle 3's Operation Current (Right)
30321	Main EEV's Status Value of Cycle 3 (Left)
30322	Main EEV's Status Value of Cycle 3 (Right)
30323~30324	Reserve
30325	Discharge Temperature of Cycle 3's Inverter Compressor1
30326	Discharge Temperature of Cycle 3's Inverter Compressor2
30327	Intake Temperature of Cycle 3's Inverter Compressor1
30328	Intake Temperature of Cycle 3's Inverter Compressor2
30329	Cycle 3's Liquid Pipe Temperature (Left)
30330	Cycle 3's Liquid Pipe Temperature (Right)
30331	Cycle 3's Hex Temperature (Left)
30332	Cycle 3's Hex Temperature (Right)
30333~30344	Reserve
30345	Accumulated Operation Time of Cycle 3's Inverter Compressor 1 (Upper Level)
30346	Accumulated Operation Time of Cycle 3's Inverter Compressor 1 (Lower Level)
30347	Accumulated Operation Time of Cycle 3's Inverter Compressor 2 (Upper Level)
30348	Accumulated Operation Time of Cycle 3's Inverter Compressor 2 (Lower Level)
30349~39997	Reserve
39998	Product Group Info.
39999	Product Type Info.

## Holding Register

Register Address	Meaning
40001	Reserve
40002	Operation Mode Setting (0 : Cooling, 4 : Heating)
40003	Cooling Target Temperature Setting (5~20°C)
40004	Heating Target Temperature Setting (40~57°C)
40005	Control Mode Setting (On-site/Remote/Scheduled)
40006	Remote Mode Setting (Contact /Modbus)
40007	Cooling Type Setting (0 : Normal, 3 : Low Temperature)
40008	Max. Operating Frequency Setting (0 : 120, 1 : 130, 2 : 110, 3 : 100, 4 : 90, 5 : 80, 6 : 70)
40009~40022	Reserve

**Check List**

## 1 Project information

Content	Information
Project name	
Address	
Installed by	
Sold by	
Test run by	

## 2 Model information

Content	Information		
Product	Model name: Serial:	Model name: Serial:	Model name: Serial:
Compressor A	Model name: Serial:	Model name: Serial:	Model name: Serial:
Compressor B	Model name: Serial:	Model name: Serial:	Model name: Serial:

## 132 APPENDIX

## 3 Preparation checklist

Content	Check	
Is there any damage?	Yes	No
Is the bolt/nut assembled properly?	Yes	No
Does the power specification match the product specification?	Yes	No
Is the wiring done accurately?	Yes	No
Is the product installed correctly?	Yes	No
Are the protective devices of the electric circuit installed correctly in accordance with the specification?	Yes	No
Are all the terminal blocks connected properly?	Yes	No
Are all plugs connected properly?	Yes	No

## 4 Check cold water system

Content	Check	
Are all valves connected to the chiller open?	Yes	No
Are all pipes connected accurately?	Yes	No
Is there any clog for drain pipe?	Yes	No
Is there any leakage?	Yes	No
Is the air within the system well discharged?	Yes	No
Is the cold water pump operating properly?	Yes	No
Is the cold water pump starter connected to the chiller properly?	Yes	No
Is the cold water flow switch operating?	Yes	No
Is the strainer installed on the pipe to the evaporator?	Yes	No

Product fiche<sup>1</sup>Manufacturer<sup>2</sup>

LG Electronics Inc.

Model Number <sup>3</sup> (Outdoor unit)	Refrigerant <sup>4</sup> (kg)	t-CO2eq
ACHH020LBAA.AAAAAAE	R410A(14)	29.23
ACHH040LBAA.AAAAAAE	R410A(28)	58.45
ACHH060LBAA.AAAAAAE	R410A(42)	87.68
ACAH020LBAA.AAAAAAE	R410A(15)	31.31
ACAH040LBAA.AAAAAAE	R410A(30)	62.63
ACAH060LBAA.AAAAAAE	R410A(45)	93.94

\* t-CO2eq = F-gas (kg) x GWP / 1000

GWP(Global warming potential)<sup>5</sup>

Refrigerant leakage contributes to climate change. Refrigerant with lower global warming potential (GWP) would contribute less to global warming than a refrigerant with higher GWP, if leaked to the atmosphere. This appliance contains a refrigerant fluid, R-410A with a GWP equal to 2087.5. This means that if 1 kg of this refrigerant fluid would be leaked to the atmosphere, the impact on global warming would be 2087.5 times higher than 1 kg of CO2, over a period of 100 years. Never try to interfere with the refrigerant circuit yourself or disassemble the product yourself and always ask a professional.

- (EN) Product fiche (BG) Продуктов фийш (ES) Ficha del producto (CZ) Informační list (DK) Datablad (DE) Produktdatenblatt (EE) Tootekirjeldus (GR) Δελτίο προϊόντος (FR) Fiche produit (HR) Informacijski list proizvoda (IT) Scheda prodotto (LV) Ražojuma speciāla zīme (LT) Gaminių vardinii parametru lentelė (HU) Gaminio vardinii parametru lentelė (MT) Skeda tal-prodott (NL) Productkaart (PL) Karta produktu (PT) Ficha de produto (RO) Fișa produsului (SK) Opis výrobku (SL) Podatkovna kartica izdelka (FI) Tuoteseloste (SE) Produktblad (GA) Meabhánán táirge (SR) Резиме производа (MK) Информативен лист (NO) Produktinformasjon (SQ) Peshkrimi i produktit (IS) Upplysingablað vöru (BS) Rezime proizvoda
- (EN) Supplier's name or trade mark (BG) име или търговска марка на доставчика (ES) Nombre o marca comercial del proveedor (CZ) název nebo ochranná známka dodavatele (DK) Leverandørens navn eller varemærke (DE) Name oder Warenzeichen des Lieferanten (EE) tarnija nimi või kaubamärk (GR) επωνυμία ή εμπορικό σήμα του προμηθευτή (FR) nom du fournisseur ou marque (HR) naziv ili zaštitni znak dobavljača (IT) nome o marchio del fornitore (LV) piegādātāja nosaukums vai preču zīme (LT) tiekėjo pavadinimas arba prekės ženklas (HU) tiekėjo pavadinimas arba prekės ženklas (MT) isem i-fornitur jew i-marka kummerċjali (NL) naam van de leverancier of het handelsmerk (PL) nazwa dostawcy lub znak towarowy (PT) Nome do fornecedor ou marca registada (RO) denumirea sau marca de comerț a furnizorului (SK) meno dodávateľa alebo jeho ochranná známka (SL) dobaviteljevo ime ali blagovna znamka (FI) tavaramittojen nimi tai tavamerkki (SE) Leverantörens namn eller varumärke (GA) Ainm an tsoláthraí nó trádmharc (SR) Назив или заштитни знак добављача (MK) Име на снабдувачот или трговска марка (NO) Leverandørens navn eller varemærke (SQ) Emri i furnizuesit apo markës tregtare (IS) Nafn birgðasala og vörumerki (BS) Naziv ili zaštitni znak dobavljača
- (EN) Model identifier of the indoor air conditioner or of the indoor and outdoor elements of the air conditioner (BG) идентификатор на модела (ES) Identificador del modelo (CZ) identifikační značka modelu (DK) Modelidentifikation (DE) Modellkennung (EE) ruumis kasutatava kliimaseadme mudelitähis või ruumis ja väljas asuvate kliimaseadmesade mudelitähised (GR) αναγνωριστικό του μοντέλου του κλιματιστικού (FR) référence du modèle de climatiseur (HR) dobavljačeva identifikacijska oznaka unutarnjeg klimatizacijskog uređaja ili unutarnjih i vanjskih elemenata klimatizacijskog uređaja (IT) identificatore del modello del condizionatore (LV) iekšējais gaisa kondicionētāja modeļa identifikators vai gaisa kondicionētāja iekšējais un ārā elementu modeļu identifikatori (LT) vidaus oro kondicionieriaus arba patalpoje ir lauke esančių oro kondicionieriaus mazgų modelio žymuo (HU) vidaus oro kondicionieriaus arba patalpoje ir lauke esančių oro kondicionieriaus mazgų modelio žymuo (MT) i-identifikatur tal-mudell ta-kundizzjonatur tal-arja ta 'gawwa jew ta-elementi tal-kundizzjonatur tal-arja ta 'gawwa jew ta barra (NL) typeaanduiding (PL) oznaczenie modelu klimatyzatora wewnętrzny lub elementów wewnętrznych bądź zewnętrznych klimatyzatora (PT) Identificador de modelo (RO) identificatorul de model (SK) ideantifikačný kód modelu vnútorného klimatizátora alebo vnútorných a vonkajších prvkov klimatizátora (SL) identifikacijska oznaka notranje klimatske naprave (FI) sisälmostointilaitteen tai huoneilmastointilaitteen sisältä ulkoyksiköiden mallinumero (SE) Modellbeteckningen (GA) Sainnítheantóir múnla den aerchóirtheoir laistigh nó de pháirteanna laistigh agus lasmuigh an aerchóirtheora. (SR) Identifikator modela unutrašnjeg klima uređaja ili unutrašnjih i spoljnih elemenata klima uređaja. (MK) Identifikacijski broj na model na vantrajniot klimatizer ili na vantrajnite i nadvorешnite elemente na klimatizerot. (NO) Modell identifikator av innendørs klimaapparat eller av innedel og utedel på klimaapparatet. (SQ) Identifikuesi modelit i kondicionerit ajorit të brendshëm apo elementeve të brendshme dhe të jashtme të kondicionerit ajorit. (IS) Auðkenni gerðar loftæstibúnaðar innanrya eða áhrifaþattir innan- og utandyra loftæstibúnaðar. (BS) Identifikator modela unutarnjeg klima uređaja ili unutarnjih i vanjskih elemenata klima uređaja.
- (EN) Refrigerant (BG) Хладилен (ES) Refrigerante (CZ) Chladiva (DK) kølemiddel (DE) Kältemittel (EE) külmutsaine (GR) ψυκτικό μέσο (FR) réfrigérant (HR) rashladnog (IT) refrigerante (LV) Aukstumaģenta (LT) Šaldalo (HU) Szálsó (MT) refrigerant (NL) koelmiddel (PL) chłodniczego (PT) refrigerante (RO) agent frigorific (SK) chladiva (SL) hladilo (FI) Kylmäainetta (SE) köldmedium (GA) Cuisneán (SR) Расхлађивач (MK) Средство за лађење (NO) Kjølemiddel (SQ) Frigoriferi (IS) Kæliefni (BS) Rashladivač
- (EN) Refrigerant leakage contributes to climate change. Refrigerant with lower global warming potential (GWP) would contribute less to global warming than a refrigerant with higher GWP, if leaked to the atmosphere. This appliance contains a refrigerant fluid with a GWP equal to [xxx]. This means that if 1 kg of this refrigerant fluid would be leaked to the atmosphere, the impact on global warming would be [xxx] times higher than 1 kg of CO2, over a period of 100 years. Never try to interfere with the refrigerant circuit yourself or disassemble the product yourself and always ask a professional. (BG) „Изпускането на хладилен агент допринася за изменението на климата. Хладилен агент с по-нисък потенциал за глобално затопляне (ПГЗ) би допринесъл по-малко за глобалното затопляне, отколкото хладилен агент с по-висок ПГЗ при евентуално изпускане в атмосферата. Настоящият уред съдържа хладилен агент с ПГЗ в размер на [xxx]. Това означава, че ако 1 kg от хладилния агент бъде изпуснат в атмосферата, въздействието за глобално затопляне ще бъде [xxx] пъти по-голямо, отколкото от 1 kg CO2 за период от 100 години. Никога не се опитвайте да се намесвате в работата на кръга на хладилния агент или сами да разглобявате уреда, а винаги се обръщайте към специалист.“ (ES) Las fugas de refrigerante contribuyen al cambio climático. Cuando mayor sea el potencial de calentamiento global (GWP) de un refrigerante, más contribuirá a dicho calentamiento su vertido a la atmósfera. Este aparato contiene un líquido refrigerante con un GWP igual a [xxx]. Esto significa que, si pasara a la atmósfera 1 kg de este líquido refrigerante, el impacto en el calentamiento global sería, a lo largo de un periodo de 100 años, [xxx] veces mayor que si se vertiera 1 kg de CO2. Nunca intente intervenir en el circuito del refrigerante ni desmontar el aparato usted mismo; consulte siempre a un profesional. (CZ) Únik chladiva se podílí na změnu klimatu. Chladivo s nižším potenciálem globálního oteplování (GWP) by se v případě úniku do ovzduší podílelo na globálním oteplování méně než chladivo s vyšším GWP. Toto zařízení obsahuje chladicí kapalinu s GWP ve výši [xxx]. To znamená, že pokud by do ovzduší unikl 1 kg této chladicí kapaliny, dopad na globální oteplování by byl v horizontu 100 let [xxx] krát vyšší než 1 kg CO2. Nenařušte chladicí oběh ani sami výrobek nedemontujte, vždy se obraťte na odborníka. (DK) «Kølemiddeludslip medvirker til klimaforandringerne. Slipper kølemiddel ud i atmosfæren, bidrager det mindre til den globale opvarmning, hvis dets potentiale for global opvarmning (GWP) er lavt, end hvis det er højt. Dette apparat indeholder en kølevæske, hvis GWP-tal er [xxx]. Det betyder, at lækket 1 kg af dette kølemiddel til atmosfæren, så vil det gennem en periode på 100 år bidrage [xxx] gange mere til den globale opvarmning end 1 kg CO2. Proov aldrig at pille ved kølemiddelkredsløbet eller at skille produktet ad selv - overlad altid det til en fagmand.» (DE) „Der Austritt von Kältemittel trägt zum Klimawandel bei. Kältemittel mit geringerem Treibhauspotenzial tragen im Fall eines Ausstrittens weniger zur Erderwärmung bei als solche mit höherem Treibhauspotenzial. Dieses Gerät enthält Kältemittel mit einem Treibhauspotenzial von [xxx]. Somit hätte ein Ausströten von 1 kg dieses Kältemittels [xxx] Mal größere Auswirkungen auf die Erderwärmung als 1 kg CO2, bezogen auf hundert Jahre. Keine Arbeiten am Kältekreislauf vornehmen oder das Gerät zerlegen – stets Fachpersonal hinzuziehen.“

## Annex (EN/BG/CS/DK/DE/EE/GR/FR/HR/IT/LV/LT/HU/MT/NL/PL/PT/RO/SK/SL/SE/GA/SRMK/NO/SQ/IS/BS)

- 5 (EE) Kõlmutusaine leke hoogustab kliima soojenemist. Atmosfääri sattumisel annab madalama ülemaimset soojenemist põhjustava mõju (GWP) väärtusega külmutusaine väiksema panuse ülemaimsesse kliimasoojenemisse kui kõrgema GWP väärtusega külmutusaine. Seade sisaldab külmutusvedelikku, mille GWP väärtus on [xxx]. See tähendab, et kui 1 kg seda külmutusvedelikku satub atmosfääri, annab see 100 aastal jooksul [xxx] korda suurema panuse ülemaimsesse kliimasoojenemisse kui 1 kg CO<sub>2</sub>. Ärge kunagi püüdke ise muuta külmutusaine voolusüsteemi, samuti ärge püüdke seadet ise koost lahiti võtta, vaid pöörduge alati spetsialisti poole. (GR) «Διαρροή ψυκτικού μέσου συμβάλλει στην κλιματική αλλαγή. Εάν διαρρεύσει στην ατμόσφαιρα ψυκτικό μέσο με χαμηλότερο δυναμικό θέρμανσης του πλανήτη (GWP) θα συμβάλει λιγότερο στην υπερθέρμανση του πλανήτη από ψυκτικό με υψηλότερο GWP. Αυτή η συσκευή περιέχει ψυκτικό μέσο με GWP ίσο με [xxx]. Αυτό σημαίνει ότι εάν διαρρεύσει στην ατμόσφαιρα 1 kg του ψυκτικού μέσου, οι επιπτώσεις στην υπερθέρμανση του πλανήτη θα είναι [xxx] φορές μεγαλύτερες από 1 kg CO<sub>2</sub>, σε περίοδο 100 ετών. Ποτέ μην επιχειρήσετε να επιβείτε στο κύκλωμα ψυκτικού μέσου ή να αποσυναρμολογήσετε το προϊόν και πάντως να απευθυνόμαστε σε επαγγελματία.» (FR) «Les fuites de réfrigérants accentuent le changement climatique. En cas de fuite, l'impact sur le réchauffement de la planète sera d'autant plus limité que le potentiel de réchauffement planétaire (PRP) du réfrigérant est faible. Cet appareil utilise un réfrigérant dont le PRP est égal à [xxx]. En d'autres termes, si 1 kg de ce réfrigérant est relâché dans l'atmosphère, son impact sur le réchauffement de la planète sera [xxx] fois supérieur à celui d'1 kg de CO<sub>2</sub>, sur une période de 100 ans. Ne tentez jamais d'intervenir dans le circuit frigorifique et de démonter les pièces vous-même et adressez-vous systématiquement à un professionnel.» (HR) «Istjecanje rashladnih sredstava doprinosi klimatskim promjenama. U slučaju ispuštanja u atmosferu rashladno sredstvo s nižim potencijalom globalnog zagrijavanja (GWP) manje bi utjecalo na globalno zagrijavanje od rashladnog sredstva s višim GWP-om. Taj uređaj sadrži rashladnu tekućinu s GWP-om jednakim [xxx]. To znači da u slučaju istjecanja 1 kg te rashladne tekućine u atmosferu, njezin utjecaj na globalno zagrijavanje bio [xxx] puta veći od utjecaja 1 kg CO<sub>2</sub> tijekom razdoblja od 100 godina. Nikada sami ne pokušavajte raditi bilo kakve zahvate na rashladnom krugu niti rastavljati proizvod i za to uvijek zovite profesionalca.» (IT) «La perdita di refrigerante contribuisce al cambiamento climatico. In caso di rilascio nell'atmosfera, i refrigeranti con un potenziale di riscaldamento globale (GWP) più basso contribuiscono in misura minore al riscaldamento globale rispetto a quelli con un GWP più elevato. Questo apparecchio contiene un fluido refrigerante con un GWP di [xxx]. Se 1 kg di questo fluido refrigerante fosse rilasciato nell'atmosfera, quindi, l'impatto sul riscaldamento globale sarebbe [xxx] volte più elevato rispetto a 1 kg di CO<sub>2</sub>, per un periodo di 100 anni. In nessun caso l'utente deve cercare di intervenire sul circuito refrigerante o di disassemblare il prodotto. In caso di necessità occorre sempre rivolgersi a personale qualificato.» (LV) Aukstumāģentu noplūdes veicina klimata pārmaiņas. Aukstumāģenta noplūdes gadījumā ierīces ar zemāku aukstumāģenta globālās sasīšanas potenciālu (GSP) nodara mazāku kaitējumu vidi. Šajā ierīcē atrodas dzesēšanas šķidrums, kura globālās sasīšanas potenciāls GSP ir [xxx]. Tas nozīmē, ka, ja vide nokļūst 1 kg šā dzesēšanas šķidruma, ietekme uz globālo sasīšanu 100 gadu laikā ir [xxx] reizes lielāka nekā 1 kg CO<sub>2</sub>. Nekādā gadījumā neiejaucieties dzesēšanas šķēdes darbībā un nemēģiniet izjaukt ierīci. Vienmēr uzticiet to kvalificētam speciālistam. (LT) Šaldalo nutekis prisideda prie klimato kaitos. Jei šaldalo nutekėtų į atmosferą, mažesni visuotinio atšilimo potencialia turintis šaldalas mažiau prisidėtų prie visuotinio atšilimo negu didesni visuotinio atšilimo potencialia turintis šaldalas. Šiame prietaise yra skysto šaldalo, kurio visuotinio atšilimo potencialas yra [xxx]. Tai reiškia, kad jei 1 kg šio šaldalo nutekėtų į atmosferą, poveikis visuotiniam atšilimui būtų [xxx] kartų didesnis negu 1 kg CO<sub>2</sub> nuotėkio per 100 metų. Nekada nebandykite patys taisyti šaldalo kontūrą ar išrinkti prietaisą. Visuomet kreipkitės į profesionalus! (HU) Šaldalo nutekis prisideda prie klimato kaitos. Jei šaldalo nutekėtų į atmosferą, mažesni visuotinio atšilimo potencialia turintis šaldalas mažiau prisidėtų prie visuotinio atšilimo negu didesni visuotinio atšilimo potencialia turintis šaldalas. Šiame prietaise yra skysto šaldalo, kurio visuotinio atšilimo potencialas yra [xxx]. Tai reiškia, kad jei 1 kg šio šaldalo nutekėtų į atmosferą, poveikis visuotiniam atšilimui būtų [xxx] kartų didesnis negu 1 kg CO<sub>2</sub> nuotėkio per 100 metų. Nekada nebandykite patys taisyti šaldalo kontūrą ar išrinkti prietaisą. Visuomet kreipkitės į profesionalus. (MT) «Lir-lixax ta' refrigerant jikkontribwixxi għat-ibidil fi-klima. Meta jiġi rilaxxat fi-atmosfera, Refriġerant b'potenzjal għat-ibidil globali (GWP) baxx jikkontribwixxi inqas għat-ibidil fi-klima milli Refriġerant b'livell ogħla ta' GWP. Dan i-taġmirhin fi fluwidu refriġeranti li GWP ta' [xxx]. Dan ifisser li jekk fi-atmosfera jiġi rilaxxat 1 kg minn dan i-fluwidu refriġerant, l-impatt tat-taħlil globali jkun [xxx] drabi akbar minn 1 kg ta' CO<sub>2</sub>. Fuq perjodu ta' 100 sena, Oatt ma għandek tipprova tbaġħbas fi-ċirkwit ta-refriġerant jew iżżamma l-prodott waħdek; dejjem tliob għal għajuna professjonali.» (NL) «Lekkage van koelmiddel leid tot klimaatverandering. Bij lekkage in de lucht draagt een koelmiddel met een laag aardopwarmingsvermogen (GWP) minder bij tot de opwarming van de aarde dan een koelmiddel met een hoog GWP. Dit apparaat bevat een koelmiddel met een GWP gelijk aan [xxx]. Dit houdt in dat als 1 kg van deze koelbloevoel in de lucht vrijkomt, het effect op de aardopwarming over een periode van 100 jaar [xxx] keer groter zou zijn dan bij het vrijkomen van 1 kg CO<sub>2</sub>. Laat het koelcircuit steeds ongemeend en probeer nooit het product zelf te demonteren; vraag dit steeds aan een vakman.» (PL) «Wycieki czynników chłodniczych przyczyniają się do zmiany klimatu. W przypadku przedostania się do atmosfery czynnik chłodniczy o niższym współczynniku ocieplenia globalnego (GWP) ma mniejszy wpływ na globalne ocieplenie niż czynnik o wyższym współczynniku GWP. Urządzenie zawiera płyn chłodniczy o współczynniku GWP wynoszącym [xxx]. Powyższe oznacza, iż w przypadku przedostania się 1 kg takiego płynu chłodniczego do atmosfery, jego wpływ na globalne ocieplenie byłby [xxx] razy większy niż wpływ 1 kg CO<sub>2</sub> w okresie 100 lat. Nigdy nie należy samodzielnie manipulować przy obiegu czynnika chłodniczego lub demontować urządzenia, należy zawsze zwrócić się o pomoc specjalisty.» (PT) «A fuga de fluido refrigerante contribui para as alterações climáticas. Os fluidos refrigerantes com menor potencial de aquecimento global (PAG) contribuem menos para o aquecimento global do que os fluidos refrigerantes com maior PAG, em caso de fuga para a atmosfera. Este aparelho contém um fluido refrigerante com um PAG igual a [xxx]. Isto significa que, se ocorrer uma fuga de 1 kg deste fluido refrigerante para a atmosfera, o seu impacto no aquecimento global será [xxx] vezes mais elevado do que o de 1 kg de CO<sub>2</sub>, durante um período de 100 anos. Nunca tome a iniciativa de intervir no circuito do fluido refrigerante ou de desmontar este produto; recorra sempre a um profissional.» (RO) «Scurgerea de agent frigorific contribuie la schimbările climatice. Dacă s-ar scurge în atmosferă, agentul frigorific cu un potențial de încălzire globală (GWP) mai redus ar contribui într-un mod mai puțin semnificativ la încălzirea globală decât un agent frigorific cu un GWP mai ridicat. Acest aparat conține un fluid refrigerant cu un GWP egal cu [xxx]. Această înseamnă că, dacă 1 kg din acest fluid refrigerant s-ar scurge în atmosferă, impactul asupra încălzirii globale ar fi [xxx] ori mai mare decât 1 kg de CO<sub>2</sub> pe o perioadă de 100 de ani. Nu încercați să intervenți în circuitul agentului frigorific sau să demontați singur produsul, apelați întotdeauna la un specialist.» (SI) «Ujicila hladiva prispevajo k zmenje klimati. Hladivo s nižjim potencialom prispevanja ku globalnemu otepljenju (GWP) by pri uniku do atmosfere prispele ku globalnemu otepljenju v nižjeji mere ako hladivo s višjim GWP. Tota zariadenie obsehuje hladilacu kvapalino s GWP ravnajicim sa [xxx]. Znamená to, že ak by do atmosfere unikol 1 kg tejšto hladilacju kvapaliny, jej vplyv na globalne otepljenie by bol [xxx] krát vyšši ako vplyv 1 kg CO<sub>2</sub> a to počas obdobia 100 rokov. Nikdy sa nepokúšajte zasahovať do chladiaceho okruhu alebo demontovať výrobok a vždy sa obráťte na odborníka.» (SL) «Puščanje hladilnih sredstev prispeva k podnebnim spremembam. V primeru izpusta v ozračje bi hladilno sredstvo z nižjim potencialom globalnega segrevanja (GWP) k globalnemu segrevanju prispevalo manj kot hladilno sredstvo z višjim GWP. Ta naprava vsebuje hladilno tekočino z GWP enakim [xxx]. To pomeni, da bi bil v obdobju 100 let vpliv na globalno segrevanje v primeru izpusta v ozračje 1 kg zadevne hladilne tekočine [xxx] večji od 1 kg CO<sub>2</sub>. Nikoli ne poskušajte sami spremeniti hladilnega obtoka ali razstaviti napravo in za to vedno prosite strokovnjaka.» (FI) «Kylmäainevuodot vaikuttavat ilmastomuutokseen. Kylmäaineen, jolla on alhaisempi ilmakehän lämmityskaikupotentiaali (GWP), ilmastomuutosvaikutus olisi pienempi kuin korkeamman GWP-arvon kylmäaineen, jos kylmäainetta päässi ilmakehään. Tämä laite sisältää kylmäainetta, jonka GWP-arvo on [xxx]. Tämä tarkoittaa, että jos yksi kilo tätä kylmäainetta päässi ilmakehään, sen vaikutus ilmaston lämpenemiseen olisi [xxx] kertaa suurempi kuin yhdellä kilolla hiilidioksidia 100 vuoden ajanjaksoilla. Älä koskaan yritä kajoita kylmäainepiiriin tai purkaa tuotetta omin päin, vaan pyydä aina ammattilaisen apua.» (SE) «Läckage av köldmedium bidrar till klimatförändringen. Köldmedium med lägre global uppvärmingspotential (GWP) skulle vid läckare ge upphov till mindre global uppvärmning än ett köldmedium med högre GWP. Den här apparaten innehåller ett köldmedium med GWP motsvarande [xxx]. Det betyder att om 1 kg av köldmediet skulle läcka ut i atmosfären, skulle påverkan på den globala uppvärmningen vara [xxx] gånger högre än 1 kg CO<sub>2</sub> under en hundraårsperiod. Försök aldrig själv montera isår produkten eller mixtra med köldmediekretsloppet. Rådfråga alltid en fackutbildad person.» (GA) «Cuirream lígean cuisneáin leis an athnú aeráide. Bheadh líonchar ní ba líu ar théamh domhanda ag cuisneán ag a bhfuil achamhain téimh domhanda (GWP) níos ísle ná ag cuisneán le GWP níos airde, má ligtear san atmaisféar é. Tá leacht cuisneáin le GWP is comhionann le [xxx] sa ghélas seo. Ciallaíonn sé seo, má ligtear 1kg den leacht cuisneáin seo san atmaisféar, is é an líonchar a bheadh ar théamh domhanda ná [xxx] uair níos airde ná 1kg de CO<sub>2</sub> thar thréimhse 100 bliain. Ná déan iaracht choíche a chur isteach ar chiorcad an cuisneáin tú féin nó an tairge a dhíchóimeáil tú féin agus téigh i gcomhairle le duine cáiliúil i gdoimh. (SR) Цурење расхлађивача доприноси климатским променама. Расхлађивач са нижим потенцијалом глобалног загревања (GWP) мање ће допринети глобалном загревању него расхлађивач са вишим потенцијалом глобалног загревања, ако исури у атмосферу. Овај уређај садржи расхлађну течност са потенцијалом глобалног загревања једнаким [xxx]. Ово значи да, ако 1 кг ове расхлађне течности исури у атмосферу, утицај на глобално загревање ће бити [xxx] пута већи него 1 кг CO<sub>2</sub>, за период од преко 100 година. Никада не покушавајте сами да подешавате расхлађно коло или да демонтирате производ и увек се обратите стручном лицу. (MK) Истекувањето на средство за ладење допринесува во климатската промена. Средство за ладење со пониж потенцијал на глобално затоплување ќе допринесе помалку во глобалното затоплување отколку средство за ладење со повисок потенцијал на глобално затоплување, ако истечено во атмосферата. Овој апарат содржи средство за ладење со потенцијал на глобално затоплување од [xxx]. Тоа значи дека ако 1 кг од ова средство за ладење истече во атмосферата, влијанието во глобалното затоплување би бил [xxx] пати повисок од 1 кг на CO<sub>2</sub>, преку период од 100 години. Никогаш да не се обидуваате да се мешате во колото на средството за ладење или самите да го расклопувате производот и секогаш побарајте професионалец. (NO) Lekkasje av kjølemiddel bidrar til klimaendring. Kjølemiddel med lavere global oppvarmingspotensial (GWP) vil bidra mindre til global oppvarming enn et kjølemiddel med høyere GWP, hvis lekket til atmosfæren. Dette apparatet inneholder en kjølevæskemed en GWP lik [xxx]. Dette betyr at dersom 1 kg av denne kjølevæskens kille bifts lekket ut i atmosfæren, ville virkningen på global oppvarming være [xxx] ganger høyere enn 1 kg CO<sub>2</sub>. I løpet av en periode på 100 år. Prov aldri å fikse med kjølekreten selv eller å demontere produktet selv og spor alltid en profesjonell. (SQ) Rijeđnja nga frigoriferi kontribon nëndryshimet e klimës. Frigoriferat me potencial më të ulët të ngrohjes globale (GWP) do të kontribonin më pak në ngrohjen globale sesa frigoriferi me GWP më të lartë, në rast të njërijshes në atmosferë. Kjo pajisje përmban lëng të frigoriferit me GWP ekuivalente me [xxx]. Kjo nënkupton se në rast se 1 kg nga ky lëng i frigoriferit do të rrihte në atmosferë, ndikimi në ngrohjen globale do të ishte [xxx] herë më i lartë se 1 kg të CO<sub>2</sub>, për një periudh prej 100 vitesh. Kurë më tentoni të ndërmeri me qarkun e frigoriferit në mënyre vetanake apo shpërbëni vetë produktin dhe gjithmonë kërkoni profesionistin. (IS) Kælielnaekli stuðlár að loftslagsbreytingum. Kælielni sem er með lægni hitunarstyrk (GWP) stuðlár minna að hlýnun jarðar en kælielni með hærrí GWP ef það myndi leka út í andrúmsloftið. Þetta tekki inniheldur kælielnaevökva sem samsavarar GWP [xxx]. Þetta þýðir að ef 1 kg af þessum kælielnaevökva myndi leka út í andrúmsloftið myndu áhrif á hlýnun jarðar vera [xxx] sinnum meiri en af 1 kg af CO<sub>2</sub>, yfir 100 ára tímabil. Fiktbó aðrei sjálf við hringrás kælielnaevökva og takið vöruna aðrei í sundur án þess að ráðfæra ykkur við fagmann. (BS) Čurenje rashladivača doprinosi klimatskim promjenama. Rashladivač sa nižim potencijalom globalnog zagrijavanja (GWP) manje će doprinjeti globalnom zagrijavanju nego rashladivač sa višim potencijalom globalnog zagrijavanja, ako iscuri u atmosferu. Ovaј uređaj sadrži rashladnu tečnost sa potencijalom globalnog zagrijavanja jednakim [xxx]. Ovo znači da, ako 1 kg ove rashladne tečnosti iscuri u atmosferu, uticaj na globalno zagrijavanje će biti [xxx] puta veći nego 1 kg CO<sub>2</sub>, za period od preko 100 godina. Nikada ne pokušavajte sami da podešavate rashladno коло ili da demonstrirate proizvod i uvijek se obratite stručnom licu.